



S-2

Installation Instructions

Covering - Fire Stops & Attic Insulation Shields

Read Sheet GS for important clearance and safety precautions before installing any of the parts described by this sheet. Sheet GS is packaged with Supports.

⚠ WARNING

Failure to follow the instructions could cause **FIRE, CARBON MONOXIDE POISONING, OR DEATH**. If you are unsure of installation requirements, call the Phone Number listed on the instructions or sizing handbook.

FIRESTOPPING

Wherever a chimney passes through a ceiling or floor, through a wall, or into an enclosure, it must be firestopped. Selkirk Chimney System (MCS) parts which act as fire stops include:

1. Ceiling Support (CSP), and Finish Support Package (FSP). Their primary use is for chimney support, but the round or square trim plate on the part is specifically intended to close and firestop the framed opening around the chimney.
2. Insulated Wall Thimble (IWT) for use in passing the MCS through a wall. (See separate instructions).
3. Fire Stop/Joist Shield (JS) for use (with all MCS models) in vertical enclosures where the MCS passes through a floor / ceiling opening. It can be either under the ceiling or between the finish ceiling and the joists (see Fig. 1).

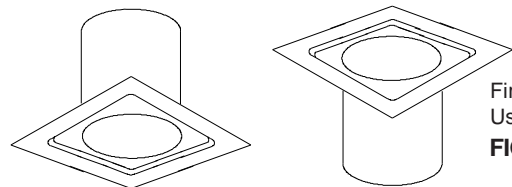

Firestop/Joist Shield (JS)
Used With MCS Chimney
FIG 1

4. Fire Stop/Trim Plate - TPS (with supplemental JS), for use with all MCS models at exposed ceilings. (See Figures 2 & 4).

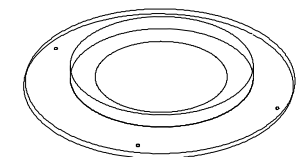

Trim Plate Spacer (TPS) For
Open Flat Ceilings Used With
MCS Chimney
FIG 2

5. Attic Insulation Shield (AIS or AIS-R), used wherever a Ceiling Support, Finish Support, or Fire Stop is installed below an open attic (see Figures 5, 7 and 8).

A fire stop performs the following essential functions for both the dwelling and the chimney:

1. Together with a fully framed opening (all four sides) it controls vertical and horizontal spread of any fire external to the chimney.
2. It stabilizes the chimney in the framed opening and defines and maintains the required two inch AIR SPACE clearance to combustibles.
3. It reduces heat losses from the dwelling by blocking vertical air circulation in the space around the chimney.
4. When located at a ceiling below a roof flashing (or below a roof support) it helps provide stability for that portion of the chimney extending above the roof.

INSTALLATION REQUIREMENTS

The selected type of Fire Stop must be the correct size for the chimney. It will usually be installed from below and secured either to the underside of the framed opening, or to the ceiling.

The Fire Stop/Joist Shield (JS) may be either under the ceiling or between the finish ceiling and the joists (see Fig. 3).

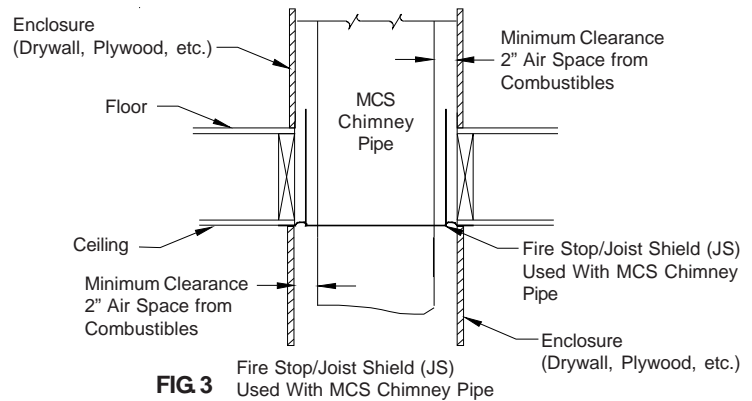

FIG 3
Fire Stop/Joist Shield (JS)
Used With MCS Chimney Pipe

The Fire Stop/Trim Plate (TPS) is intended only to be used below the ceiling (see Fig.4).

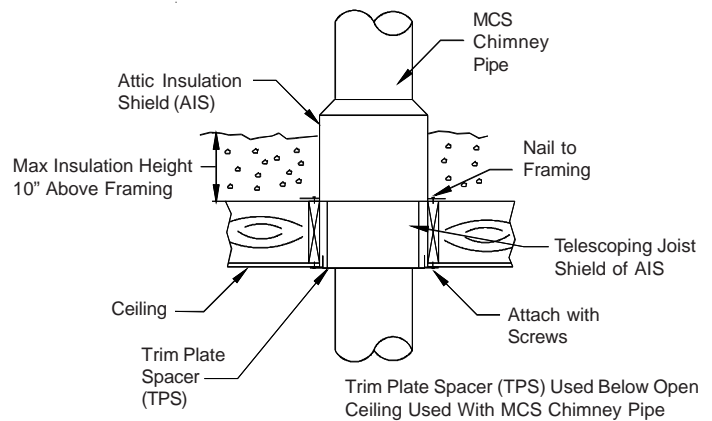

FIG 4
Trim Plate Spacer (TPS) Used Below Open
Ceiling Used With MCS Chimney Pipe

To Install:

1. Frame a level square opening for 2 inches AIR SPACE clearance from the outside of the chimney to the framing.
2. Temporarily install the JS together with a length of chimney through the opening to check chimney positioning and clearance.
3. Use nails to secure Fire Stop/Joist Shield (JS) to the framing. Use screws to secure the Fire Stop/Trim Plate (TPS).
4. If the framed opening is larger than necessary, the Fire Stop (or JS) outer edge must be extended by appropriate means (attaching metal plates, 28 gauge galvanized steel or heavier) to completely block the framed opening from a vertical air flow around the chimney. Enclose the chimney below the Fire Stop to prevent any accidental contact with the chimney. To prevent blown-in attic insulation from falling against the chimney, either use an Attic Insulation Shield (AIS or AIS-R) or a full enclosure in the attic. See Section on Attic Insulation Shields.

CHIMNEYS IN ATTICS

In attics, either use an Attic Insulation Shield (AIS or AIS-R) or enclose the chimney. The chimney must be protected against the known contact hazards of insulation or stored combustible materials - mattresses, clothing, etc. Building a full enclosure is more effective but may be difficult and costly in tight spaces where there is little risk of accidental contact. For such situations the Attic Insulation Shield should be used.

Protection against blown-in cellulose insulation is very important.

ATTIC INSULATION SHIELDS (AIS & AIS-R)

The function of the Attic Insulation Shield is to keep insulation away from contact with the chimney. Certain insulations made of cellulose fiber (old newspapers, processed wood) may ignite and smolder due to heat trapped by contact with the chimney. When this smoldering fire reaches ordinary wood framing, a flaming fire may result. However, even without a flame, a smoldering fire may create noxious gases and cause great property damage.

INSTALLATION OF THE ATTIC INSULATION SHIELD

(AIS) - 1-PART DESIGN - Sizes 5" to 8"

The Attic Insulation Shield (AIS) for chimney diameter sizes of 5" to 8" consists of an integrated storm collar and a telescoping joist shield (see Fig. 4 & 5).

The Attic Insulation Shield (AIS) allows for a depth of insulation of 10 inches plus the depth of the ceiling joists. If insulation is blown in and adheres to the chimney pipe, it should be brushed off to eliminate any possible contact of this material with the chimney when it is in use.

For proper installation, the attic opening should be fully framed incorporating the same dimensions used for the ceiling joist framing to ensure the required 2 inches AIR SPACE clearance to the chimney pipe is present. The square base of the Attic Insulation Shield (AIS) is placed on the framed opening around the chimney by inserting the spacer tabs of the base plate down within the framed opening until fully seated. Nail the AIS base to the framing with at least 2 nails per side. Extend the telescoping shield down through the framing (see Figures 4 & 5).

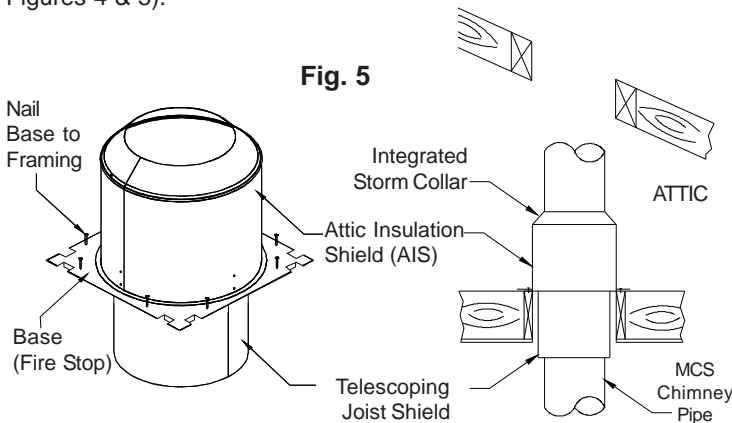

Fig. 5

NOTE: The Attic Insulation Shield (For diameters 5", 6", 7" and 8") functions as its own Fire Stop and Joist Shield eliminating the need for separate Fire Stop and Joist Shield components.

INSTALLATION OF THE ATTIC INSULATION SHIELD

(AIS-R) - 2-PART DESIGN - Sizes 5" to 14"

The 2-part Attic Insulation Shield (AIS-R) consists of two half cylinders, each with its own base plate, together with a Storm Collar (SC) closure at the upper end (see Fig. 6). It may be used for new as well as retrofit installations. For retrofit installation the Attic Insulation Shield (AIS-R) may be installed around an existing chimney without removing it. It is also adaptable to limited headroom installations near eaves of roofs where it can be slid into place, or the two halves can be installed down through a roof opening and placed around the chimney (see Fig. 7).

For proper installation, the attic opening should be fully framed at 2 inches AIR SPACE clearance to the chimney pipe with framing material of the same dimension as the ceiling joists. The square base in the AIS-R is placed on the framed opening around the chimney, with the adjoining vertical edges fully together.

After the chimney section has been installed through the AIS-R, the storm collar is then placed around the pipe and slid tightly down over the upper open end of the cylinder. Nail the AIS-R base to the framing with at least 2 nails per side.

Fig. 6
Attic Insulation Shield (AIS-R)

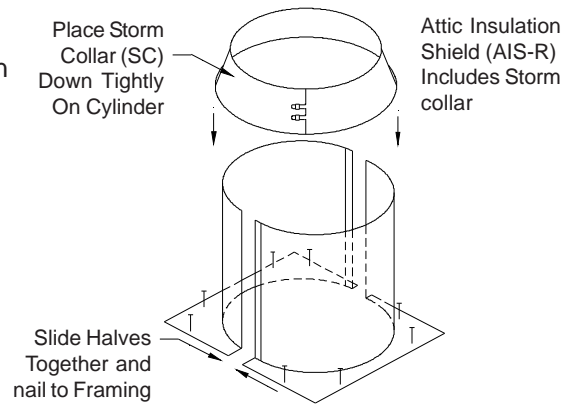

The split cylinder low profile design of the AIS-R permits it to be used close to eaves and side walls (see Fig. 7). If there is sufficient clearance the storm collar should be used. If the cylindrical shield projects through the roof it should be trimmed flush with the roof surface so it does not interfere with the flashing.

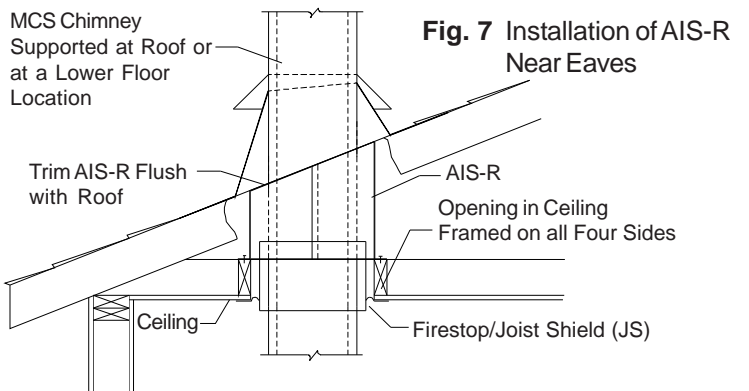

Fig. 7 Installation of AIS-R Near Eaves

The Attic Insulation Shield (AIS-R) allows for a depth of insulation of 10 inches above the framing. If insulation is blown in and adheres to the chimney pipe, it should be brushed off to eliminate any possible contact of this material with the chimney.

NOTE: The 2-Part Attic Insulation Shield (AIS-R) does not function as a Fire Stop or Joist Shield and must be used with other parts that are designated as such. Parts that serve as Fire Stops include the Ceiling Support (CSP/FSP), Fire Stop/Trim Plate-TPS (with supplemental JS), and the Fire Stop/Joist Shield (JS). An installation above a Finish Support Package is shown in Fig. 8. If the chimney system is supported at a lower level, a Fire Stop/Joist Shield must be used (see Fig. 7).

Instead of using the Attic Insulation Shield the chimney installer always has the option of fully enclosing the chimney between the ceiling framing and the roof. This enclosure should be any standard material such as drywall or plywood, at the required 2-inch AIR SPACE clearance.

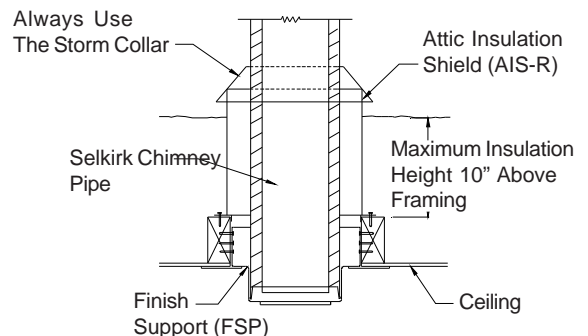

Fig. 8 AIS-R Used Over Finish Support