



SUPERVENT (SC & FC)
SUPERPRO (SPR)

FACTORY BUILT INSULATED CHIMNEY



INSTALLATION INSTRUCTIONS
&
MAINTENANCE GUIDE
(CANADA & UNITED STATES)

**A MAJOR CAUSE OF VENT
RELATED FIRES IS FAILURE TO
MAINTAIN REQUIRED
CLEARANCES (AIR SPACES) TO
COMBUSTIBLE MATERIALS.**

**IT IS OF THE UTMOST
IMPORTANCE THAT THIS
CHIMNEY SYSTEM BE
INSTALLED ONLY IN
ACCORDANCE WITH THESE
INSTRUCTIONS.**

**PLEASE READ ALL INSTRUCTIONS
BEFORE BEGINNING YOUR
INSTALLATION.
FAILURE TO INSTALL THIS SYSTEM IN
ACCORDANCE WITH THESE
INSTRUCTIONS WILL VOID THE
CONDITIONS OF CERTIFICATION AND
THE MANUFACTURER'S WARRANTY.**



Tested to
UL 103 Type HT
and
CAN/ULC-S604

*Installer: It is of the utmost importance that
these instructions are left with the homeowner.*

*Homeowner: Keep these instructions and
maintenance guide in a safe place for future
reference.*

SELKIRK CORPORATION
4460 44th Street S.E., Suite F
Grand Rapids, MI 49512
1.800.992.VENT (8368)







SELKIRK CANADA
P.O. Box 526, Depot 1
Hamilton, ON L8L 7X6
1.888.SELKIRK(735.5475)

TABLE OF CONTENTS

CERTIFICATION LABELS	3
TYPE OF APPLIANCES	4
PRE INSTALLATION GUIDELINES	4, 5
TOOLS	5
FRAMING DETAILS	5
CEILING SUPPORT INSTALLATION	5, 6
STOVE PIPE ADAPTOR	6
ADJUSTABLE LENGTH	6, 7
ATTIC INSULATION SHIELD INSTALLATION	7, 8
FIRESTOP RADIATION SHIELD INSTALLATION	8, 9
ELBOW INSTALLATION	9
WALL SUPPORT INSTALLATION (AWS)	9, 10, 11
INTERMEDIATE WALL SUPPORT (AIWS)	11
WALL SUPPORT INSTALLATION (WS)	11 - 15
WALL BANDS	15, 16
CATHEDRAL CEILING SUPPORT INSTALLATION	16, 17
RAFTER RADIATION SHIELD INSTALLATION	17
ROOF SUPPORT INSTALLATION	17
ROOF FLASHING INSTALLATION	17, 18
ROOF GUY INSTALLATION	18, 19
MAINTENANCE AND CLEANING OF CHIMNEY	20
CHART 1 - OFFSET CHIMNEY INSTALLATION	21
CHART 2 - CHIMNEY HEIGHT ABOVE THE ROOF	22
CHART 3 - CONNECTOR PIPE CLEARANCES - CATHEDRAL SUPPORT	22
REPLACEMENT PARTS LIST	23
INSTALLATION RECORD	24

CERTIFICATION LABELS

	RESIDENTIAL TYPE AND BUILDING HEATING APPLIANCE CHIMNEY PART LISTED MH6673 U.S.A.: UL 103 TYPE HT CANADA.: CAN/ULC-S604	PIECE POUR CHEMINEE MODEL / MODÈLE PREFABRIQUEE SC / SPR / FC LISTED MH6673 U.S.A.: UL 103 TYPE HT CANADA.: CAN/ULC-S604
USA	MINIMUM CLEARANCE TO COMBUSTIBLES 2" or as established by factory spacers and support assembly. Follow manufacturer installation instructions packaged with Support Assembly. For connection to solid, liquid or gas fired appliances normally producing flue gases of 1000° F or less. Suitable for interior and exterior installation. Failure to follow the installation instructions could cause Fire, Carbon Monoxide Poisoning or Death. If you are unsure of the installation requirements call the number found on the installation instructions.	 UP HAUT 
CANADA	MINIMUM CLEARANCE TO COMBUSTIBLES 2" (50 MM) or as established by factory supplied spacers and support assembly. Follow manufacturer installation instructions packaged with Support Assembly. For connections to liquid or gas fired appliances normally producing flue gases of 540° C (1000° F) or less. May also be used with specific factory-built fireplaces listed to UL 127 or CAN/ULC-S610 when specified in the fireplace manufacturer's installation instructions. SUITABLE FOR INTERIOR AND EXTERIOR INSTALLATION. Failure to follow the installation instructions could cause Fire, Carbon Monoxide Poisoning or Death. If you are unsure of the installation requirements call the number found on the installation instructions. ESPACE LIBRE MINIMALE AUX MATIÈRES COMBUSTIBLES de 2 po (50mm) ou tel que déterminé par le coupe-feu et ensemble de support. Doit être installé suivant les directives d'installation du manufacturier emballées avec le support. Pour embranchement aux appareils chauffant un combustible liquides ou à gaz produisant normalement des gaz d'échappement de 540° C (1000° F) ou moins. Peut également être utilisé sur des foyers fabriqués en usine certifiés aux normes UL 127 ou CAN/ULC-S610 lorsque spécifié dans les directives d'installation du fabricant du foyer. CONVIENT À UNE INSTALLATION INTÉRIEURE OU EXTÉRIEURE. Ne pas suivre les directives d'installation peut causer feu, empoisonnement au monoxyde de carbone ou la mort. Si vous êtes incertains aux procédures d'installation, veuillez communiquer au numéro inscrit sur les directives.	
PART NUMBER: LABEL SAMPLE NO. DE PIÈCE:		 1 23456 78901 2
SELKIRK CANADA CORPORATION STONEY CREEK, ONTARIO 09/29/20		123456789012345678 12345678901234567890123 12 1002869

	RESIDENTIAL TYPE AND BUILDING HEATING APPLIANCE CHIMNEY PART LISTED MH6673 U.S.A.: UL 103 TYPE HT CANADA: CAN/ULC-S604	PIECE COMPOSANTE POUR APPAREIL DE CHAUFFAGE DE TYPE LISTED MH6673 U.S.A.: UL 103 TYPE HT CANADA: CAN/ULC-S604
FOR USE WITH SELKIRK MODELS SC/SPR/FC LABELLED FACTORY-BUILT CHIMNEYS		À UTILISER AVEC LES CHEMINÉES MODÈLE SC/SPR/FC PORTANT UNE ÉTIQUETTE
PART NUMBER: LABEL SAMPLE NO. DE PIÈCE:		 1 23456 78901 2
SELKIRK CANADA CORPORATION STONEY CREEK, ONTARIO 09/29/20		12 1002868

TYPE OF APPLIANCES

U.S.A. APPLICATIONS

In the U.S.A., Model SuperVent/SuperPro has been tested per UL103 as a "Type HT" chimney by Underwriters Laboratories, Inc. As such it is code approved for connection to solid, liquid or gas fueled appliances in which the maximum continuous flue gas temperatures do not exceed 1000°F. It has been tested and approved to withstand temperatures of up to 2100°F for three ten minutes intervals.

Factory built chimneys are intended for installation in accordance with NFPA 211 (Standard for Chimneys, Fireplaces, Vents and Solid Fuel Fired Appliances), and/or local and regional codes such as the International Mechanical Code and Uniform Mechanical Code, etc.

The flue diameter of gas or oil fired appliances should comply with the appropriate NFPA or ANSI Installation Codes; NFPA 54, ANSI Z223.1, and NFPA 31.

This chimney system is suitable for venting gas, oil or solid fuel fired appliances including wood stoves, furnaces, boilers and fireplaces.

CANADA APPLICATIONS

In Canada, Model SuperVent/SuperPro is intended for connection to liquid fuel or gas fired residential type appliances and building heating appliances, in which the maximum continuous flue gas temperatures do not exceed 540°C (1000°F) as per ULC-S604. It has been tested and approved to withstand temperatures of up to 925°C for three 30 minutes intervals.

May also be used with specific factory-built fireplaces listed to UL 127 and CAN/ULC-S610 when specified in the fireplace manufacturer's installation instructions.

The flue diameter of gas or oil appliances should comply with National and Provincial Building Code of Canada and appropriate Installation Codes; CAN/CSA-B149 for gas and CAN/CSA-B139 for oil.

PRE-INSTALLATION GUIDELINES

If you choose to have your product professionally installed, we recommend these products be installed by professionals who are certified in the U. S. by NFI (National Fireplace Institute).

Your SuperVent/SuperPro chimney and connecting stove pipe diameter should be sized in accordance with the appliance manufacturer's recommendations.

Plan the installation of your appliance and chimney in such a way that both your chimney and your stove pipe run is as short and straight as possible. By having too long and or multiple bend installations you can reduce system draft which can affect the operation, and or performance of your appliance and or chimney system. The chimney should be located within the building so as to avoid cutting or altering load bearing members such as joists, rafters, studs, etc. If you require to cut or alter an existing load bearing member, special reframing methods are required which often include doubling of adjacent members. If such a case arises, contact your local Building Code Official regarding local regulations and proper installation methods.

Sections of the SuperVent/SuperPro chimney which pass through accessible areas of the building such as through closets, storage areas, occupied spaces or any place where the surface of the chimney could be contacted by persons or combustible materials must be enclosed in a chase to avoid personal contact and damage to the chimney. The chase may be fabricated using standard building materials. Drywall

mounted on 2" x 4" studs is typically used in this situation. The space between the outer wall of the chimney and the enclosure must be a least a minimum of 2 inches.

The National Fire Protection Association Standard 211 states: Factory-built chimneys that pass through floors of buildings requiring the protection of vertical opening shall be enclosed with approved walls having a fire resistance rating of not less than 1 hour where such chimneys are located in a building less than four stories in height, and not less than 2 hours where such chimneys are located in a building four or more stories in height.

MAINTAIN A 2" MINIMUM AIR SPACE CLEARANCE BETWEEN INSULATED CHIMNEY SECTIONS AND COMBUSTIBLE MATERIALS OR AS ESTABLISHED BY SUPPORT ASSEMBLY.

WARNING: DO NOT PLACE ANY INSULATING MATERIALS OR RUN ANY ELECTRICAL WIRING WITHIN THE REQUIRED AIR CLEARANCE SPACE SURROUNDING THE CHIMNEY.

Before beginning the installation ensure that you obtain any necessary building permits, and that your installation will conform with all federal and municipal building code requirements.

CONTACT LOCAL BUILDING OR FIRE OFFICIALS ABOUT RESTRICTIONS AND INSTALLATION INSPECTION IN YOUR AREA.

An Attic Insulation Shield must be installed where the chimney passes into an attic space. It is designed to keep insulation materials or debris from coming into contact with the chimney. It must accommodate the amount of insulation as required by the National Building Code.

Where height restrictions will not permit the use of the Attic Insulation Shield, it is permissible to construct an enclosure with a 2" air space clearance to the outer pipe all the way to the underside of the roof deck. In this application you need to install a Firestop Radiation Shield on the ceiling side and a Rafter Radiation Shield at the roof level.

At the level where the chimney penetrates the air/vapour barrier, special attention is required. Seal the vapour barrier to the Firestop Spacer or Ceiling Support assembly or Wall Thimble using an appropriate caulking compound as per the requirement of local authorities.

The ideal location for your chimney is within the building envelope. In cold climates, the use of external chimneys may result in operational problems such as poor draft, excessive condensation of combustion products and rapid accumulation of creosote. Under these circumstances, the installation of the chimney within the building is strongly recommended.

If the chimney must be installed on an exterior wall it is recommended that the chimney be enclosed below the roof line to protect the chimney from cold outdoor temperatures, this may help reduce condensation, creosote formation and enhance draft. Ensure extra space is provided for an access door by the Insulated Tee for chimney inspection and cleaning. The exterior enclosure may be insulated, maintaining the required minimum air space clearance of 2" to any part of the chimney. Consult local building codes for cold climate application.

YOUR CHIMNEY HAS BEEN TESTED, AND LISTED USING ALL OF THE SUPPORTS, SHIELDS, ETC., DESCRIBED HEREIN. DELETION OR MODIFICATION OR ANY OF THE REQUIRED PARTS OR MATERIALS MAY SERIOUSLY IMPAIR THE SAFETY OF YOUR INSTALLATION, AND VOID THE CERTIFICATION AND OR WARRANTY OF THIS CHIMNEY

The use of Locking Bands at all chimney joints is recommended for added safety and stability when exposed to high winds and as a precaution against accidental unlocking of lengths when the system is inspected and swept.

Obtain any necessary building permits.

WEAR SAFETY GLOVES WHEN HANDLING SHEET METAL PARTS WITH SHARP EDGES

Authorities require that the chimney extend not less than 3 feet above the highest point where it passes through the roof of a building and not less than 2 feet above any portion of the building within 10 feet (see figure 1). See Chart 2 for Chimney Height Above the Roof on page 21 of these instructions.

FIGURE 1

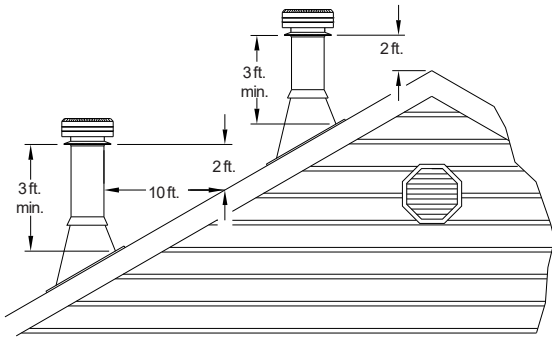

Do not install the chimney directly at the outlet of the appliance. Interconnecting stove pipe is required unless the appliance is specifically approved for this type of installation.

Use only with an appliance listed by a recognized testing authority such as Underwriters Laboratories Inc., Underwriters laboratories of Canada, or Intertek Testing Services.

Do not mix and match with other manufacturer's products. Use only Selkirk's Models JSC/SPR/JFC listed components.

CHIMNEY SIZING:

In order to achieve safe, optimum performance of the appliance, service life of the chimney, the chimney must be sized correctly for the connected appliance. In general, the chimney flue should be the same size as the appliance flue outlet. The installation should be done in accordance with the applicable installation codes (eg. CAN/CSA B149, CAN/CSA B139, NFPA 54 and NFPA 31) and appliance manufacturer instructions. Plan the installation of your appliance and chimney in such a way that both your chimney and flue pipe runs are as short and straight as possible. By having too long and/or multiple bend installations you can reduce the system draft which can affect the operation, and/or performance of your appliance and/or chimney system.

TOOLS

Your SuperVent/SuperPro chimney system is designed for installation using standard building materials and procedures. The following tools/equipment may be required as well as some others depending on the location and structure in which the chimney is to be installed:

- safety gloves
- safety goggles
- hammer and nails
- tin snips
- tape measure
- screwdrivers and pliers
- plumb line and level
- square
- keyhole saw or power jig saw
- caulking gun

FRAMING DETAILS:

Plan your installation carefully. If possible, position the stove so that the flue outlet is between joists, rafters or studs. Drop a plumb line to the center of the flue outlet and mark this center point on the ceiling. Lay out and frame in all openings ensuring the specified 2" clearance to combustibles is maintained. Refer to Table 1 and applicable Tables for framing dimensions and mark the appropriate cutting lines around the center point. All openings should be square (all four sides), plumb and in perfect alignment with each other (see figure 2).

For sloping roofs (cathedral/vaulted ceiling), ensure that the framing dimension is measured in the horizontal plane (see figure 3).

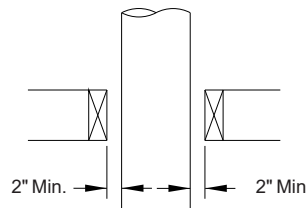

FIGURE 2
Typical Joist Framing

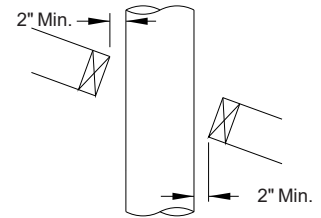

FIGURE 3
Typical Roof Joist Framing

TABLE 1

Chimney Flue Diameter		Framing Dimensions		
		Decorator Ceiling Support	Wall (Support) Thimble	All Other Framing
5 (150mm)	in.	12 ³ / ₈ x 12 ³ / ₈	14 ³ / ₈ x 14 ³ / ₈	11 x 11
	mm	315 x 315	365 x 365	280 x 280
6 (125mm)	in.	12 ³ / ₈ x 12 ³ / ₈	14 ³ / ₈ x 14 ³ / ₈	12 x 12
	mm	315 x 315	365 x 365	305 x 305
7 (175mm)	in.	13 ³ / ₈ x 13 ³ / ₈	14 ³ / ₈ x 14 ³ / ₈	13 x 13
	mm	340 x 340	365 x 365	330 x 330
8 (200mm)	in.	14 ³ / ₈ x 14 ³ / ₈	14 ³ / ₈ x 14 ³ / ₈	14 x 14
	mm	365 x 365	365 x 365	355 x 355

Note: *When cutting the inside "finished" surface of your wall or ceiling cut a "round hole" to the framing dimension.

INSTALLATION PROCEDURES:

DECORATOR CEILING SUPPORT

To complete a proper Decorator Ceiling Support installation, the following parts will or may be required:

- Decorator Ceiling Support (DCS): Required when supporting a chimney through a flat level ceiling.
- Stove Pipe Adaptor (ASE): Transition from the chimney to flue pipe.
- Attic Insulation Shield (AIS): Required where a chimney passes from a lower living space into an unoccupied attic space.
- Firestop Radiation Shield (FRS): Required where a chimney passes from a lower living space into an upper living space or occupied attic space.
- Roof Flashing Assembly (including Storm Collar): Required when the chimney penetrates a roof.
- Rafter Radiation Shield (RRS): Required when the chimney is enclosed immediately below the roof.
- Suitable lengths of Chimney: The chimney diameter (ID) should be sized to suit the appliance.

- 15° or 30° Elbow Kit: To avoid cutting of joists and clear other obstructions. Kit includes: 2 Elbows, 1 Offset Support and 4 Locking Bands.
- Rain Cap: Standard or Deluxe model.

The SuperVent/SuperPro Decorator Ceiling Support will support up to 50 feet of chimney sections, all of which must be installed above the support. Figures 4 & 10 show the 2 most common types of Ceiling Support Installation. Frame (on all 4 sides) a level square opening to the dimensions specified in the Framing Dimension Table 1.

Slide the Trim Ring onto the Decorator Ceiling Support and slide the assembly into the framed opening from below. Ensure that the finishing ring is flush with the underside of the finished ceiling and the assembly is level and plumb. Secure the ceiling support in place using at least three (3) 8-penny (2-1/2") nails through each of the 4 straps or through the 12 pre-punched holes in the support. You may substitute in lieu of nails 12 - #8 x 2" wood screws.

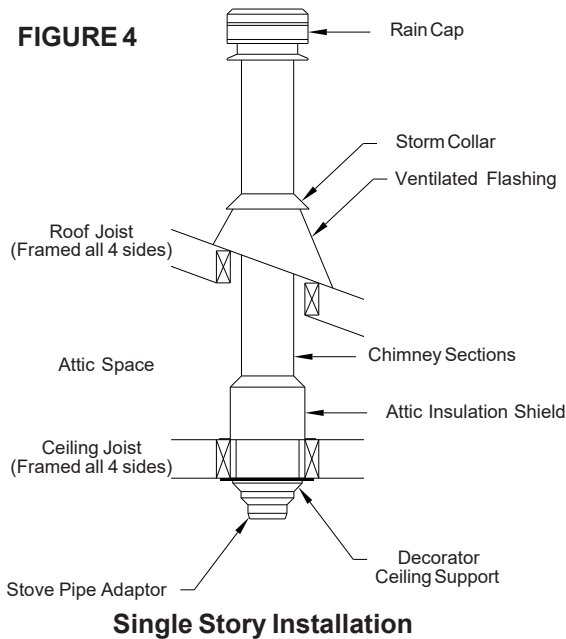

Single Story Installation

STOVE PIPE ADAPTOR (ASE)

The Stove Pipe Adaptor (ASE) is installed by twist-locking it into the bottom end (female end) of the first Chimney Section that enters the Ceiling Support. Lower the assembly down into the Decorator Ceiling Support ensuring that the stovepipe adaptor sleeve is protruding through the support and into the living space (see Figure 5). Do not install an elbow in the Ceiling Support. Make sure that the male coupler of the insulated Chimney Length is pointing upwards as indicated by the arrow on the chimney label.

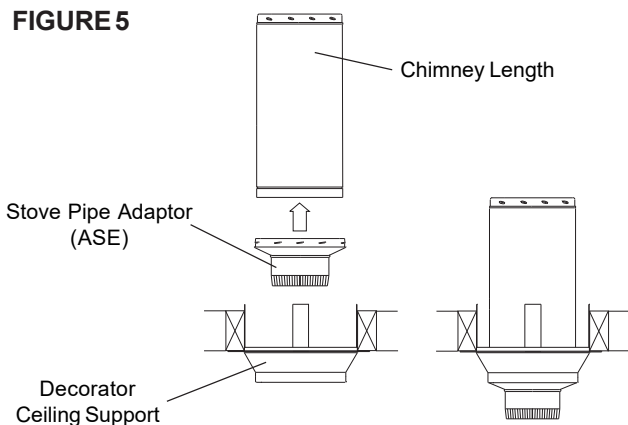

The crimped end (stub) of the Stove Pipe Adaptor is intended to fit inside of the flue pipe from a solid fuel appliance, thus preventing condensate drips at the chimney connection. Install inter-connecting flue pipe following the appliance manufacturer's installation instructions and appropriate building code requirements keeping in mind that the flue pipe run should be as short and straight as practicable. Generally, for a wood burning appliance installation, an 18" minimum clearance to combustibles must be maintained for a single wall flue pipe. The exception to this is a double wall stove pipe, such as Selkirk's **Model DSP** which can be installed at reduced clearances of 6" to combustibles. See separate installation instructions for more details.

Install additional chimney sections and lock together by turning clockwise until the two sections lock together tightly. Even though Locking Bands are optional, it is always recommended to install a locking band to secure the chimney sections. Continue adding chimney lengths until a height of about 2ft. below the next ceiling level is achieved.

NOTE: The Decorator Ceiling Support cannot be used when the chimney terminates in a room with a suspended ceiling.

When false ceilings are encountered, use a Cathedral Ceiling Support to extend into the room below the finished ceiling. The floor/ceiling joist must be framed on all 4 sides. The box must extend a minimum of 1" below the suspended ceiling. The chimney length is to protrude a minimum of 3" below the support and the trim angles must be installed.

ADJUSTABLE LENGTH (AL)

An Adjustable Length (AL) is installed between other components to establish an exact finished length, where a standard length can not be utilized. The AL has an overall length of 12" and has an installed length that adjusts from 2" to 9-1/2".

The Adjustable Length is available in diameters of 5" to 8".

The Adjustable Length must be installed above a fixed length - they cannot be installed immediately above a support, tee or elbow.

The Adjustable Length slides over the male end of an adjoining straight length. However, to allow engagement it is necessary to remove some of the insulation from the inlet end of the Adjustable Length.

Note: To facilitate installation, it is recommended that the Adjustable Length be attached and secured to the lower adjoining segment before it is installed in the system.

To install:

1. Determine (measure) the finished (installed) length of chimney needed (DIM "A") and add 2.25" to the measurement (See Fig. 6).
2. Remove the Adjustable Length from the packaging carton and set it with the male end (coupler end) of the Adjustable Length down to prevent insulation from spilling out (See Fig. 7).
3. From the male end, measure up the distance Dim "A" + 2.25" and mark a line on the Adjustable Length (See Fig. 7).
4. Measure the distance (Dim "B") from that line to the edge of the Adjustable Length and add 1". This is the "overlap" distance. On the adjoining standard length, measure up from the male coupler, the "overlap" distance and mark a reference line. Make sure the location of the reference line is measured from the standard length's male (coupler) end (See Fig 7).

5. Remove insulation from the inlet (female) end of the Adjustable Length until the insulation is level with the line marked on the outside of the pipe (See Fig. 7).

6. While still positioned with the coupler end down, insert the standard straight length into the Adjustable Length (See Fig. 8a).

7. Re-orient the assembly to the upright position (Male Coupler Up) and apply pressure to compress the adjoining segments together until the overlapped edge of the Adjustable Length extends down to the reference line marked on the standard length. Secure by installing 3 #8 x 1/2" stainless steel sheet metal screws through the pilot holes in the Adjustable Length and into the outer wall of the adjoining segment (See Fig. 8b).

8. Seal the overlap seam and screws with silicone sealant (See Fig. 8b).

9. Once the female end of the Adjustable Length is secured to the adjoining segment, the assembly may be installed in the system.

NOTE: If the Adjustable Length (AL) is installed in a system where it will be subjected to the weight of more than 4' of chimney (either above or below), supplementary support such as Roof Support (RS) is required.

10. Continue installing the remaining system parts.

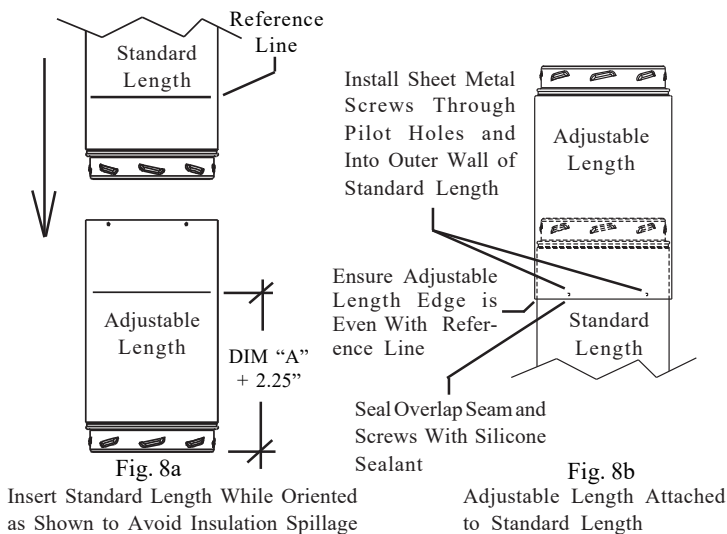
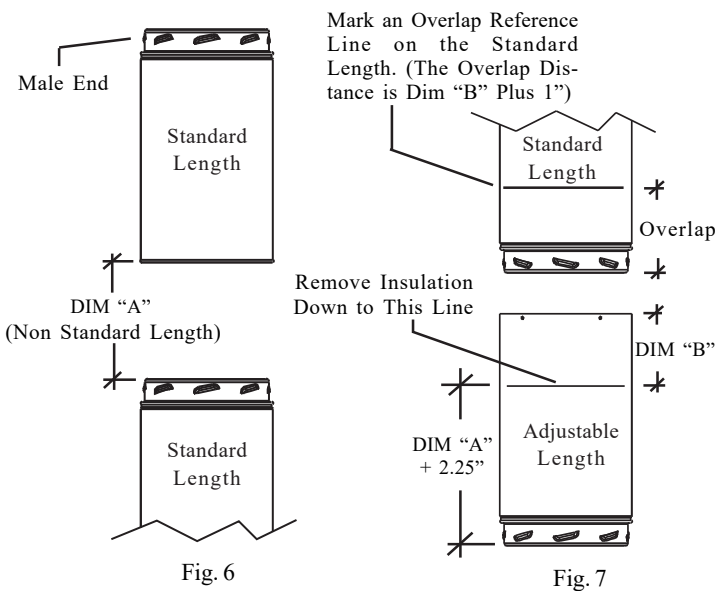

FIRESTOPPING

Firestopping is required at every joist level. Wherever a chimney passes through a ceiling or floor, through a wall, or into an enclosure, it must be firestopped. No firestopping is required in conjunction with a Ceiling Support installed as shown in Figure 13, the Ceiling Support provides the firestopping. Firestopping performs the following essential functions for both the dwelling and the chimney.

- Together with a fully framed opening (all four sides), controls vertical and horizontal spread of any fire external to the chimney.
- It stabilizes the chimney in the framed opening and defines and maintains the required AIR SPACE clearance to combustibles.
- It prevents heat losses from the dwelling by blocking vertical air circulation in the space around the chimney.
- It helps provide stability for chimney extending above the roof.
- At the level where the chimney penetrates the air/vapour barrier, special attention is required. Seal the vapour barrier to the Support Assembly, Attic Insulation Shield or Wall Thimble by using an appropriate caulking compound as per the requirement of local authorities.

ATTIC INSULATION SHIELD (AIS)

An Attic Insulation Shield (AIS) must be installed where the chimney enters an attic space (Figures 9 & 10). An Attic Insulation Shield is to keep insulation from coming into contact with the chimney and will allow a depth of insulation of 10 inches plus the depth of the ceiling joist. If insulation is blown in and adheres to the chimney pipe, it must be brushed off to eliminate any possible contact of this material with the chimney surface. The height of the Attic Insulation Shield is to meet the insulation level requirement of the National Building Code. Where height restrictions will not permit the use of the Attic Insulation Shield, it is permissible to construction an enclosure with the required air space clearance to the outer pipe all the way to the underside of the roof deck. When enclosing the chimney below the roof line, a Rafter Radiation Shield (RRS) must be installed at the roof level and a Firestop Radiation Shield (FRS) at the ceiling level.

For proper installation, the attic opening must be fully framed at 2 inches of clearance to the chimney pipe with framing material of the same stock as the ceiling joists and as per Framing Dimension Table 2 and Figure 11. The tabs on the plate of the AIS are inserted in the framed opening around the chimney. Nail the AIS base to the framing with at least 2 per side, using 2d (1") spiral nails or 1" x #8 wood screws.

NOTE: To reduce cold air infiltration into the dwelling you can install the optional Universal Shielding Insulation (JUSI) into the Attic Insulation Shield. See separate installation instructions.

FIGURE 9

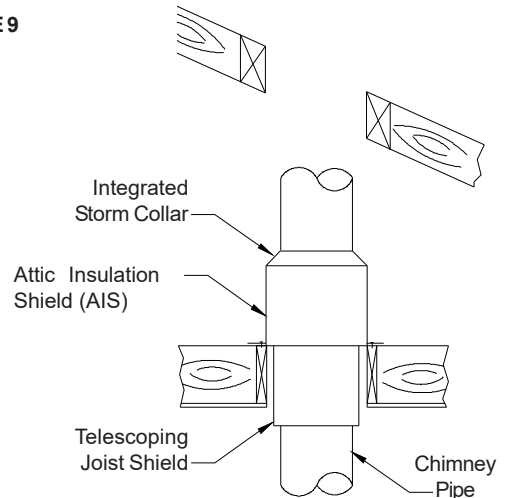

DIAMETER OF CHIMNEY	5"	6"	7"	8"
FRAMED OPENING	11 x 11	12 x 12	13 x 13	14 x 14
"A" DIM.	7 -1/4"	8 -1/4"	9 -1/4"	10 -1/4"
"B" DIM.	11"	12"	13"	14"
"C" DIM.	11-13/16"	11-13/16"	11-13/16"	11-13/16"
"D" DIM.	13"	14"	15"	16"
"E" DIM.	20"	20"	20"	20"

When an Attic Insulation Shield is required above the Decorator Ceiling Support into an attic as shown in Figure 4, ensure that the base of the shield is flush with the top of the joist framing and nail in place. The telescoping portion of the AIS will eliminate the need to trim the bottom when installed immediately above this support. When fully extended, the AIS will also provide joist shielding when installed in a 2 story main floor or basement applications (see Figures 10 & 13). If insulation is blown in and adheres to the chimney pipe, it must be brushed off to eliminate any possible contact of this material with the chimney surface.

At the level where the chimney penetrates the air/vapor barrier, special attention is required. Seal the vapour barrier to the Support or Attic Insulation Shield or Wall Thimble using an appropriate caulking compound as per the requirement of local authorities.

FIGURE 10

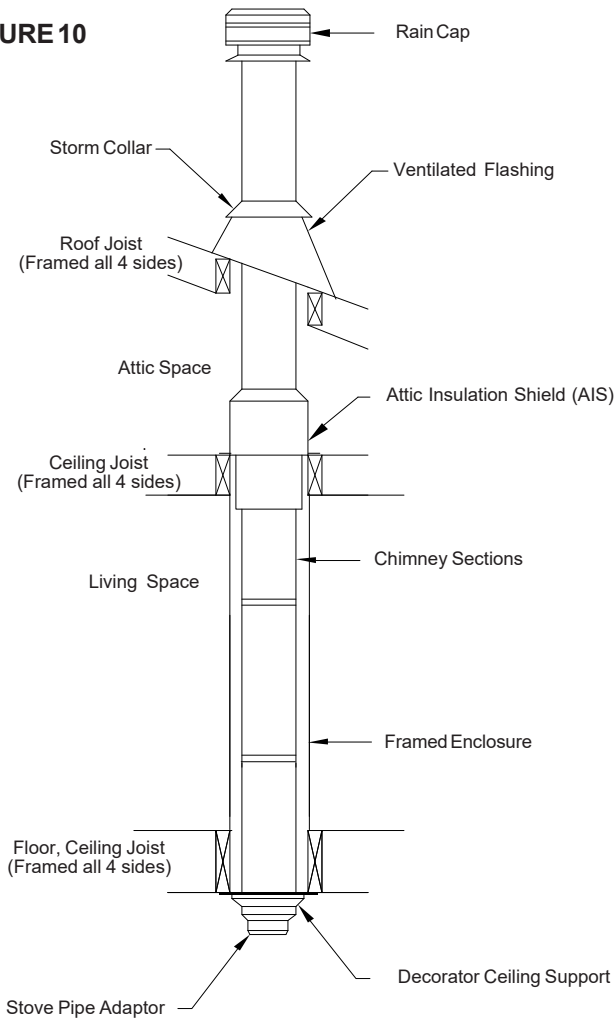

Two Story Main Floor Installation

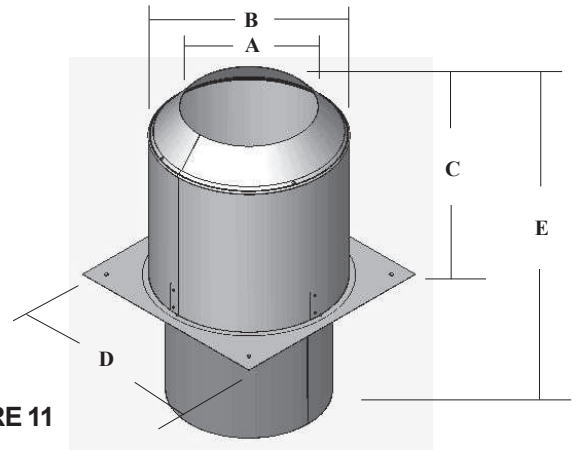
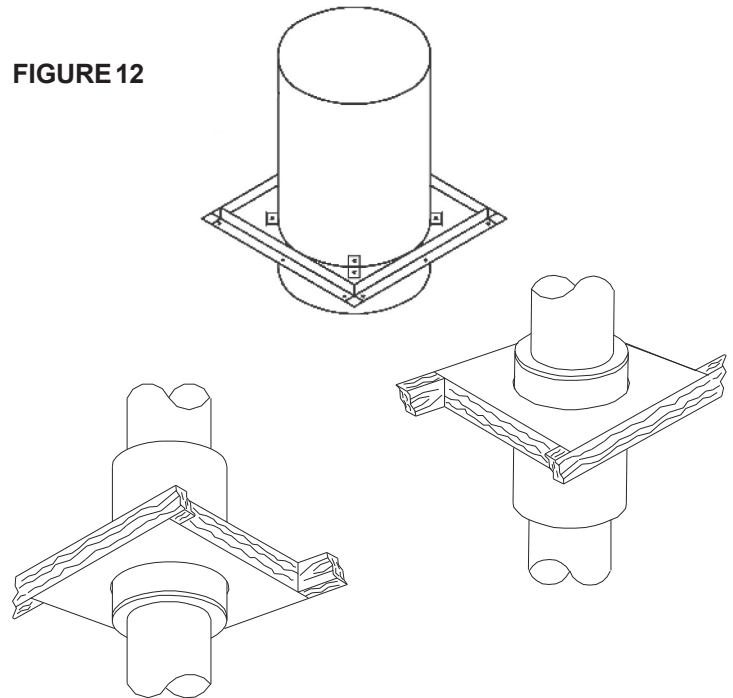

FIGURE 11

FIRESTOP RADIATION SHIELD (FRS)

A Firestop Radiation Shield (FRS) - also known as a Firestop Joist Shield, is for use in vertical enclosures where the chimney passes through a floor/ceiling opening, from one living space to another living space, as shown in figures 12 & 13. It is installed from either above or below the joist. It is designed to provide proper firestopping between floors and to keep direct radiation from the chimney away from the joist framing.

FIGURE 12



Firestop Radiation Shield Installed into Framed Joist Opening from Above or Below

Install the Firestop Radiation Shield (FRS) from below or above (Figure 12) the framing into the framed opening outlined in Table 1 and nail in place using 1" spiral nails. Ensure no insulation or debris is within the 2" air space clearance around the chimney. This includes the air space between the Firestop Radiation Shield (FRS) and the joist framing.

When the chimney is enclosed in the attic area, a Firestop Joist Shield (FRS) must be installed at the ceiling level. If the base of the Firestop Joist Shield (FRS) does not fit flush with the ceiling frame, measure the distance that the base is sitting below the framing and trim that amount off of the top of the FRS before securing into place.

FIGURE 13

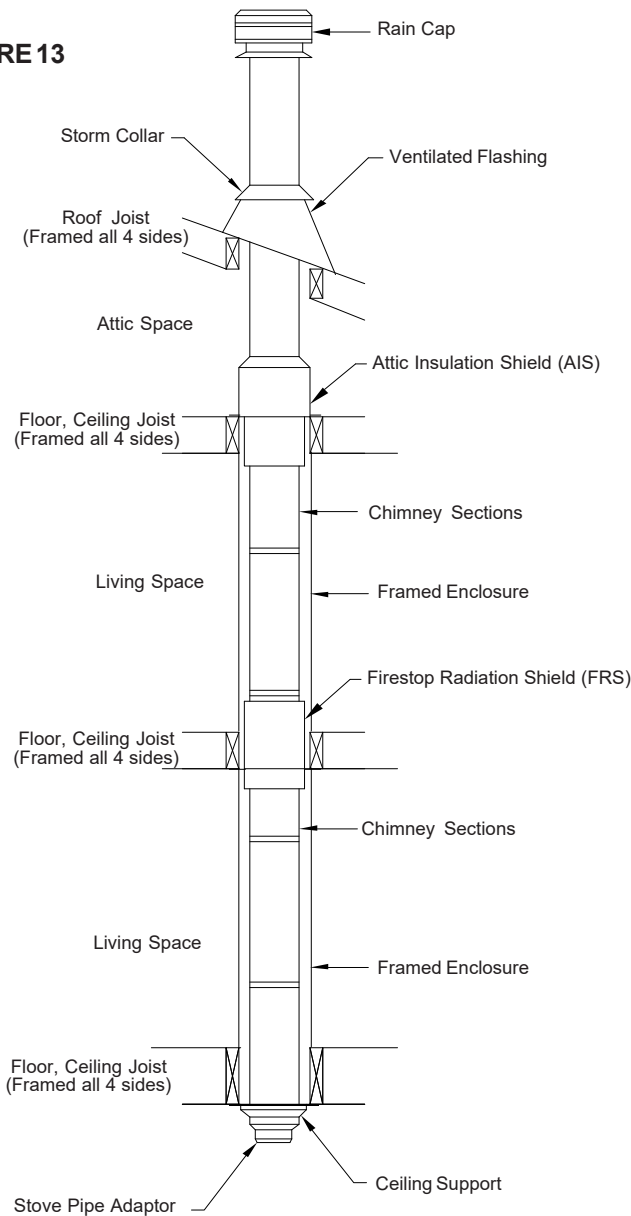

Two Story Basement Installation

ELBOW INSTALLATION

One pair of (two) Elbows may be used in an interior installation to provide an offset in order to avoid cutting of joists and to clear other obstructions. Each Elbow Support will support 15 feet of chimney and the maximum length of chimney allowed between Elbows is 6 feet. **Forty-five-degrees (45°) elbows may be used only in Canada.** See **Chart 1 - Offset Chimney Installation** on page 21 of these instructions for details.

The female end of Elbows are **not** embossed, this ensures proper alignment of the chimney system is maintained. Locking Bands must be installed at all chimney joints forming an offset.

Install the insulated offset Elbow on the vertical chimney Length and position the Elbow in the required direction. Fasten the Elbow to the chimney Length with the supplied Locking Band.

Place the required offset chimney Length(s) as per the Offset Chart 2 (page 21) for appropriate length(s). Turn it clockwise to lock it in place and fasten in place with the supplied Locking Band.

Never install an Elbow in a joist area. Chimney Lengths must pass vertically through framed joist areas.

FIGURE 14

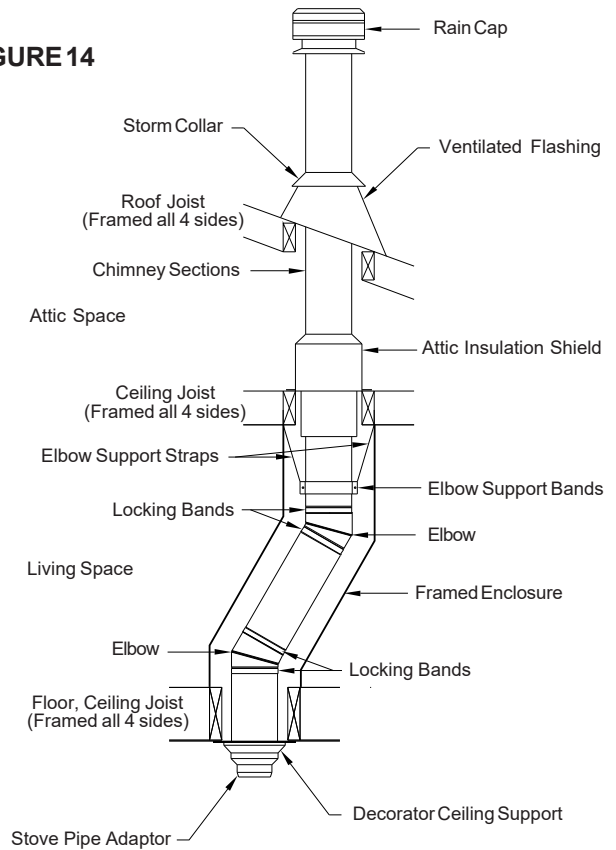

Offset (Elbow) Installation

Install the remaining offset Elbow to turn the chimney back to the vertical position and fasten in place with the supplied Locking Band. During installation provide supplementary support for the offset section to avoid undue stress on connected elbows.

Install an Elbow Support on the first Length just above the highest Elbow. Attach the Support Band to the chimney with 4 of the nuts and bolts, and then install the four stainless steel sheet metal screws through the pre-punched holes. Attach the Support Straps to the Support Band assembly and nail the Support Straps to the framing using 6d (2") nails or #8 x 1-1/2" wood screws (see figure 14).

WALL SUPPORT (AWS) - 2-1/2" only

As previously mentioned, the ideal location for your chimney system is within the building envelope. A Wall Support installation is required when the above mentioned location is not possible.

To complete a proper Wall Support installation, the following parts will or may be required:

- Adjustable Wall Support (AWS): Intended for a through-the-wall installation where the chimney has a horizontal connection. The AWS is adjustable only from 2" to 2-1/2" from the vertical wall. NOTE: The AWS is supplied in the Wall Support Kit. For greater adjustment, the WS must be ordered separately.
- Stove Pipe Adaptor (ASE): Transition from chimney to connector pipe.
- Insulated Tee with Tee Plug: Allowing a horizontal connection to the chimney.
- Roof Flashing Assembly: Required when the chimney penetrates a roof or a roof overhang.
- Rafter Radiation Shield (RRS): Required when the chimney is enclosed immediately below the roof.
- Wall Band (WB): Required to provide lateral support to chimney.
- Suitable lengths of chimney: The chimney diameter should be sized to suit the appliance.
- Wall Thimble (WT): - Required to pass through a combustible wall.
- Rain Cap: Standard or Deluxe model.

FIGURE 15

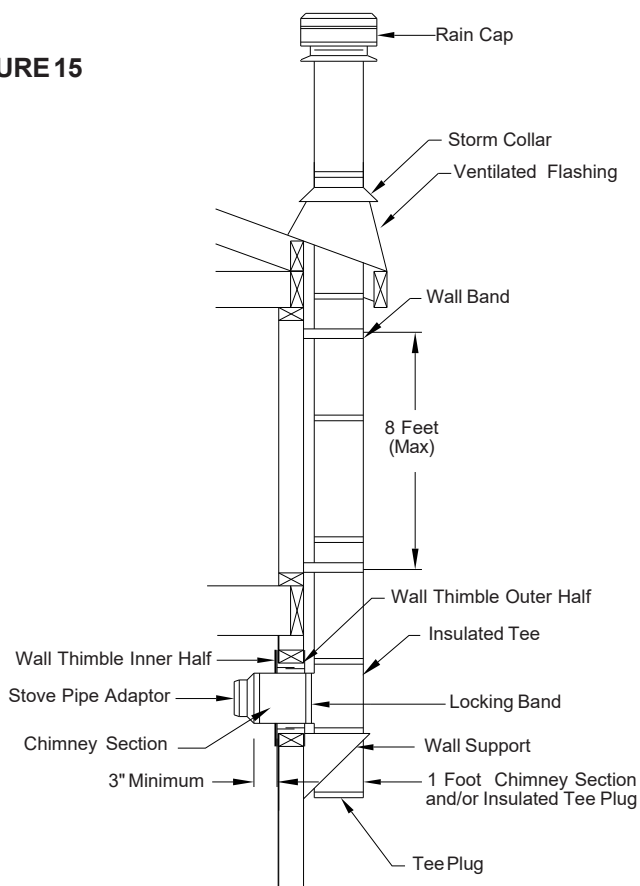

The Adjustable Wall support (AWS) will support up to 38 feet (11.5m) of chimney, all of which must be above the support with the exception of the 1 foot cleanout section and/or the Insulated Tee Plug, which is installed below the support (Figure 15).

A Wall Thimble will be required when passing through a combustible wall and will accommodate a wall thickness up to 8-3/4" (see Figure 16). After framing in your opening to the dimensions specified (see Framing Dimensions Table 1) on page 5, install the exterior outer half (with the

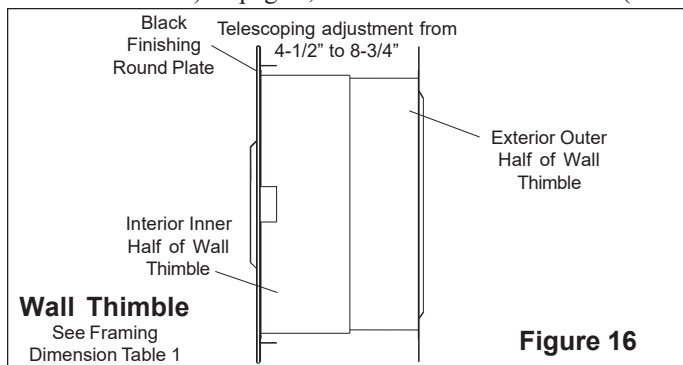

unfinished square plate) of the wall thimble into the outside wall opening. Secure in place with appropriate fasteners through the pre-punched holes.

Install the interior inner half (with round plate and tabs) of the wall thimble into the inside wall opening, ensuring that the shield slides over the shield of the exterior outer half (see Figure 16). Once in place and flush against the wall, install the black finishing trim plate (round black plate) onto the finished inside wall surface and fasten in place with appropriate fasteners through the four pre-punched holes.

NOTE: When the combustible wall thickness exceeds the telescoping range of the Wall Thimble, it is permissible to field fabricate a metal sleeve extension. The sleeve extension must be of a galvanized sheet metal of minimum 26 gauge. It must also overlap a minimum of one inch (1") over each of the thimble sleeves and be secured with a minimum of 3 rivets or screws.

For a non combustible wall, cut a hole 3/16" greater than the outside diameter of the chimney.

NOTE: To reduce cold air infiltration into the dwelling you can install the optional Universal Shielding Insulation (JUSI) into the Wall Thimble. See separate installation instructions packaged with the JUSI.

Assemble the Wall Support (Figure 17) by attaching the 2 side brackets to the support plate with the supplied hardware. Ensure that the female coupler attached to the underside of the support plate is facing down. For an adjustment of the support plate, align the fixed holes on the support plate with the elongated holes on the side brackets.

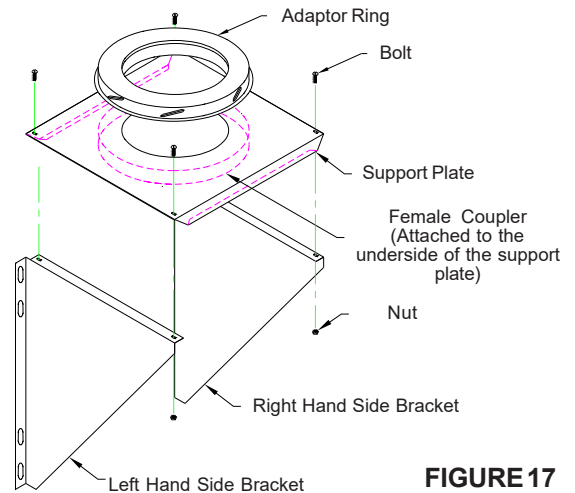

FIGURE 17

NOTE: THE CHIMNEY MUST EXTEND AT LEAST 3" (75 MM) INTO THE LIVING SPACE WHERE THE STOVE PIPE CONNECTOR WILL BE ATTACHED TO THE CHIMNEY BRANCH.

Install an appropriate Insulated Chimney Length such as a one foot (or longer if required-not to exceed 24 inch) Length of Insulated Chimney to the horizontal branch of the Insulated Tee.

Lock securely into the Tee branch by twisting clockwise. A Locking Band must then be installed to secure the connection. Make sure the nut and bolt are facing down to prevent any water from collecting in the Locking Band. The Tee branch extension must protrude a minimum of 3" into the room.

NOTE: Ensure that you have set aside the Tee Plug, if not, do so now as you will require it later.

From outside the building, slide the assembly (Chimney Length installed on the Tee branch) through the Wall Thimble ensuring the male coupling on the Tee is facing upward. Insert and twist lock the Adaptor Ring in the female coupler of the Insulated Tee (bottom of Tee). Place the assembled Wall Support against the wall (support plate facing up) directly below the Tee. Slide the Wall Support up to the Tee ensuring that the stub of the Adaptor Ring (Figure 17) is inserted into the opening of the Support Plate.

Prior to securing ensure that the Insulated Tee assembly is plumb, level and sitting flush on the Support Plate. Secure to the wall through the pre-punched holes located on each side of the Wall Support Brackets using eight (8) #14 x 1/2" hex head lag screws or #10 x 2" wood screws. Make sure they go into solid bracing. If the support is properly positioned, these lag bolts will go into wall studs placed on 16" centers. For concrete block or poured foundation use suitable fasteners.

Use a non-hardening high-temperature silicone sealant (500°F) to seal around the horizontal chimney length where it enters through the exterior of the Wall Thimble or the concrete wall.

Twist lock a 12" section into the Female Coupler beneath the Support Plate. Twist lock the Tee Plug into the bottom of the section. You can substitute an Insulated Tee Plug (1TPI) for the 12" section.

Chimney Lengths above the Insulated Tee are simply stacked on and locked with a 1/8 clockwise turn. It is highly recommended to secure all exterior chimney joints with Locking Bands (SLB).

For lateral stability of the chimney above the Wall Support, a Wall Band must be installed along an outside wall. Install the first Wall Band midway up the first Chimney Length above the Insulated Tee. Any additional Wall Bands are to be installed at 8 foot intervals above this point.

The nut and bolt supplied will fasten the band around the chimney.

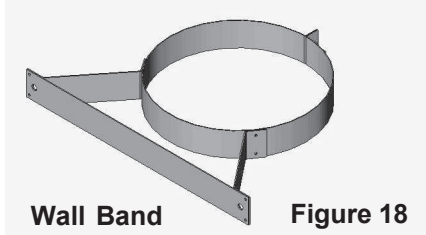

Securely fasten the Wall Band around the chimney with the supplied nut and bolt. Check for clearances and plumb as you fasten the Wall Bands to the wall. Use a level against the chimney section at each support stage to keep the assembly plumb.

Secure the Wall Band bracket to the wall using two 6d (2") spiral nails or #8 x 2" wood screws or longer if required through the pre-drilled holes (see Figure 18). For concrete or brick veneer walls use suitable masonry fasteners.

If roof overhangs the wall of the structure so that passage of the chimney is obstructed, it is necessary to cut an opening in the overhang. Allow the minimum 2" air space clearance to combustible. To find the exact spot where the chimney will pass through the overhang, drop a plumb line from the underside to the outer edge of the leveled chimney length. Mark 5 or 6 points to give an outline of the hole. Keep in mind the 2" clearance to the chimney outer surface. Install an Attic Insulation Shield if space permits on the under side of the overhang. If it is not possible, the overhang can be enclosed and a Rafter Radiation Shield installed at the roof level and a Finishing Plate on the underside. If the Attic is open to the overhang, close off the access with suitable building materials ensuring that a 2" air space clearance is maintained. From above, install the Roof Flashing and Storm Collar by following the Roof Flashing section in these instructions.

If the overhang is not deep enough to allow the chimney to be fully installed within the overhang, it will be necessary to cut away a portion of the overhang. Ensure that a 2" minimum air space clearance all around the chimney is established. Framing and flashing the sides of the opening with suitable sheet metal will be required. Install a Wall Band fastened securely to the wall structure directly beneath the overhang. The installation of a Universal Roof Brace Kit may be required if the chimney exceeds 5 feet or more above the roof.

NOTE: Interior chimneys installed with a Wall Support must use a Firestop Radiation Shield (FRS) in place of Wall Bands if extending through floor/ceiling penetrations and an Attic Insulation Shield when passing through an unoccupied attic space.

ADJUSTABLE INTERMEDIATE WALL SUPPORT (AIWS)

If the total chimney height exceeds the Wall Support (AWS) limitations an Adjustable Intermediate Wall Support must be installed. Use of an AIWS will support an additional 38ft. of chimney. The AIWS is adjustable from 2" to 2-1/2" only from the vertical wall. Slide the assembled Intermediate Wall Support over the protruding length of chimney. Fasten the Intermediate Wall Support to the wall using four 1/4" by 2" wood screws through the pre-punched slots in each bracket. Install the draw band around the protruding chimney length securely against the support plate. Install four stainless steel sheet metal screws firmly into the outer casing of the chimney, through the pre-punched holes in the draw band. Cover the heads of the screws with a non-hardening waterproof caulking.

NOTE: If a greater adjustment is required, such as to clear an overhang, the WS Wall Support must be installed. This support is ordered separately.

WALL SUPPORT (WS) - Adjustable up to 6" from a vertical wall (sold separately)

As previously mentioned, the ideal location for your chimney system is within the building envelope. A Wall Support installation is required when the above mentioned location is not possible.

To complete a proper Wall Support installation, the following parts will or may be required:

- Wall Support (WS): Intended for a through-the-wall installation where the chimney has a horizontal connection. The WS is adjustable from 2" to 6" from the vertical wall. **NOTE:** The WS is NOT supplied in the Wall Support Kit.
- Stove Pipe Adaptor (ASE): Transition from chimney to flue pipe.
- Insulated Tee with Insulated Tee Cap: Allowing a horizontal connection to the chimney.
- Roof Flashing Assembly: Required when the chimney penetrates a roof or a roof overhang.
- Rafter Radiation Shield (RRS): Required when the chimney is enclosed immediately below the roof.
- Wall Band (WB); Universal Wall Band (UWB): Required to provide lateral support to chimney.
- Suitable Lengths of Chimney: The chimney diameter should be sized to suit the appliance.
- Chimney Length: Appropriate length for connection to Tee branch.
- Wall Thimble (WT): Required to pass through a combustible wall.
- Rain Cap: Standard or Deluxe model

The maximum chimney height above a Wall Support is indicated in Table 4 and illustrated in Figure 19, all of which must be above the support.

The Wall Support will allow for an adjustment of 2" to 6" from a vertical wall. Threaded studs are factory installed on both side brackets and the support plate for fast and easy assembly (see Figure 122).

Ensure the Wall Support Brackets are bolted securely to the wall .

The following steps will assist you in the installation of the Wall Thimble and of the Wall Support. Figure 19 shows a typical Wall Support installation through a combustible wall.

1. Determine the centre line of the horizontal connection (Chimney Length through the wall) and frame an opening to the dimensions specified for the Wall Thimble in a combustible wall. See Section A in Table 3 and Figure 21 (A).

- Use a stud finder to roughly locate the walls studs. Mark the

outline of the hole and drill a pilot hole in its center.

- Break out part of the wall covering within the outline to confirm that the hole will be centered between studs and that no electrical wires could be cut by the saw.

2. For a non-combustible wall (concrete block or poured foundation), cut a hole (3/16") greater in diameter than the outside diameter of the chimney as per Table 3.

3. After framing in your opening to the dimensions specified to the Framing Tables 1 or 3, install the outer half (with the unfinished square plate) of the Wall Thimble into the outside wall opening. Secure in place with appropriate fasteners through the pre-punched holes.

FIGURE 19

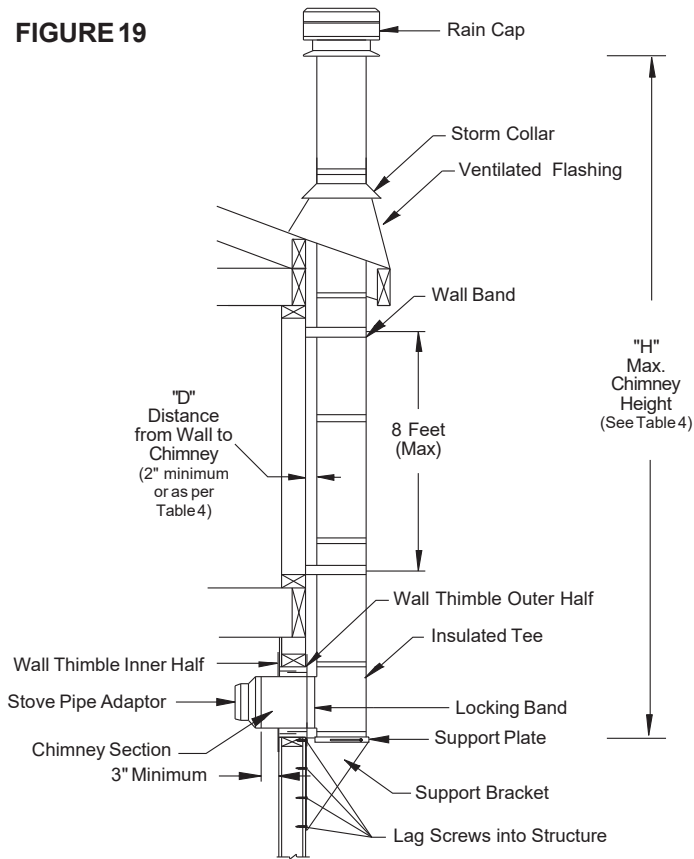

See Table 4 for maximum Chimney Heights based on Chimney Diameter and Distance from Wall

Distance from Wall to Chimney	Table 4 - Wall Support Chimney Height Chart			
	5" ID Chimney	6" ID Chimney	7" ID Chimney	8" ID Chimney
D (inches) Wall/Chimney	H(feet) Max. Height	H (feet) Max. Height	H (feet) Max. Height	H (feet) Max. Height
2	74	63	56	49
2.5	73	62	55	48
3	71	60	53	47
3.5	69	59	51	46
4	66	56	49	44
4.5	62	53	46	42
5	58	50	43	39
5.5	52	45	38	35
6	45	39	34	30

D - Distance from wall to the chimney

H - Height of chimney in feet

See Figure 10 also.

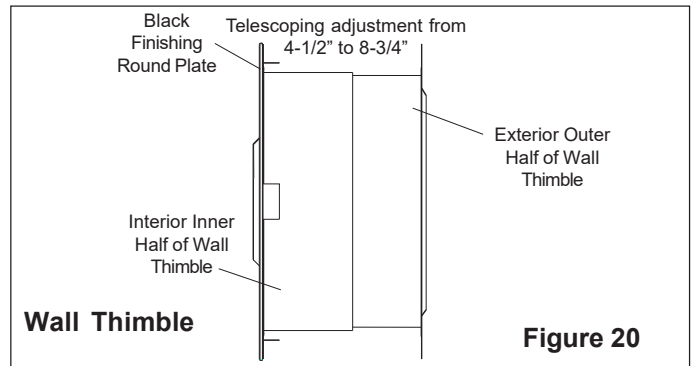

4. Install the inner half (with round plate) of the Wall Thimble into the inside wall opening, ensuring that the shield slides over the shield of the outer half. Once in place and flush against the wall, install the black finishing trim plate onto the wall surface and fasten in place with appropriate fasteners through the 4 pre-punched holes.

NOTE: To reduce cold air infiltration into the dwelling you can install the optional Universal Shielding Insulation (JUSI) into the Wall Thimble. See separate installation instructions packaged with the JUSI.

Table 3 - Framing Dimensions Wall Thimble & Support Brackets		Chimney Size (ID)			
		5"	6"	7"	8"
	Minimum Round Hole Diam. For Non-Combustible Wall	7-3/16"	8-3/16"	9-3/16"	10-3/16"
A	Wall Thimble Minimum Framed Opening for Combustible Wall	14-3/8"	14-3/8"	14-3/8"	14-3/8"
B	Support Brackets Minimum Framed Opening For Bracing	9-1/4"	9-1/4"	10-1/4"	11-1/4"

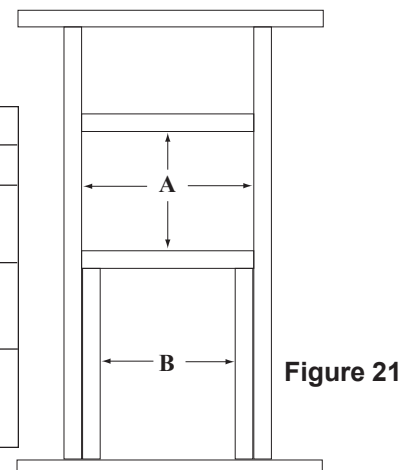

5. Assemble the 2 side Brackets (point of triangle facing down) to the Support Plate (flange up and threaded stud towards the wall) by inserting the threaded studs into the oblong slots (see Figures 22 & 23). Install the supplied nuts on the threaded studs until snug, do not tighten at this time as adjustments may be required. Set aside and prepare the support bracing to secure the side brackets as per the Framing Dimensions Table 3, Section B and Figure 21 (B).

Two options are described below for the installation of the Wall Support and the Insulated Tee assembly. Follow Method A if inserting an assembled Insulated Chimney Length and Insulated Tee into the Wall Thimble prior to the Wall Support. Follow Method B if securing of the Wall Support to the wall prior to the Insulated Tee and the Insulated Chimney Length.

METHOD A

6. Install an appropriate Insulated Chimney Length such as a one foot section (or longer if required-not to exceed 24 inches) to the horizontal branch of the Insulated Tee. Lock securely into the Tee branch by twisting clockwise. A Locking Band must then be installed to secure the connection. Make sure the nut and bolt are facing down to prevent any water from collecting in the Locking Band. The Tee branch extension must protrude a minimum of 3" into the room.

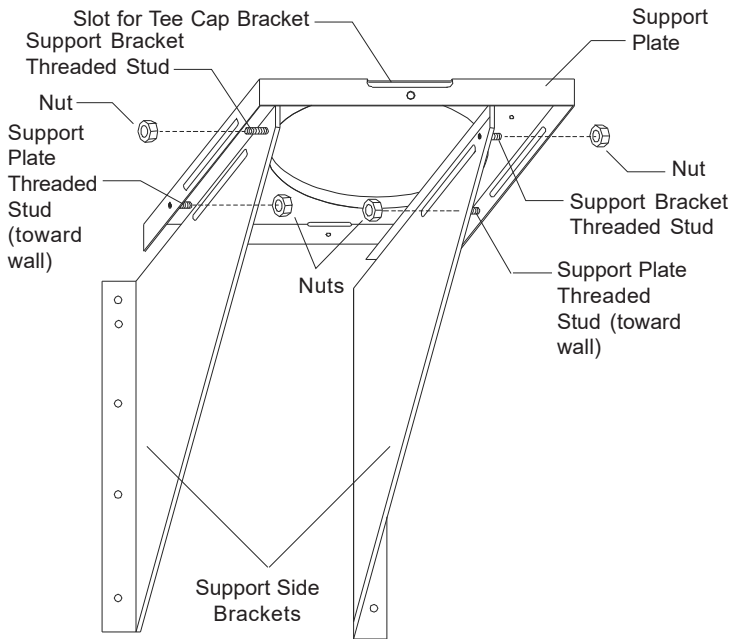

FIGURE 22
UNDERSIDE VIEW OF THREADED STUDS AND NUTS

7. From outside the building, slide the assembly (Chimney Length installed on the Tee Branch) through the Wall Thimble ensuring the male coupling on the Tee is facing upward. The Wall Thimble will provide support until you are ready to install the Wall Support Assembly.

8. Place the assembled Wall Support against the wall (Support Plate Flange up) directly below the Insulated Tee. Slide the Wall Support up to the bottom of the Insulated Tee ensuring that the flange on the top of the Support Plate is inserted into the female coupler.

9. Prior to securing ensure that the Insulated Tee assembly is plumb and level and sitting flush on the Support Plate. Secure to the wall through the pre-punched holes located on each side of the Wall

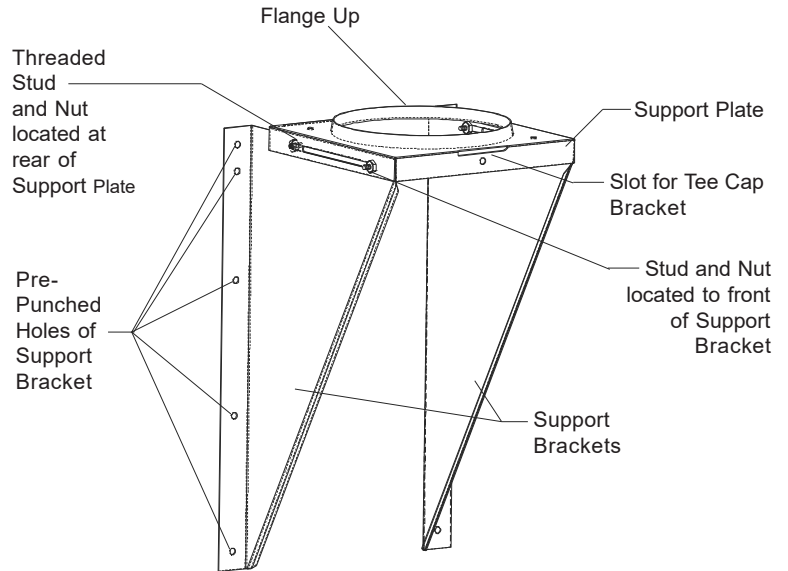

FIGURE 23
FRONT VIEW OF WALL SUPPORT ASSEMBLY

NOTE: THE CHIMNEY LENGTH MUST EXTEND AT LEAST 3" THROUGH THE WALL INTO THE LIVING SPACE WHERE THE STOVE PIPE CONNECTOR WILL BE ATTACHED TO THE CHIMNEY BRANCH.

Support Brackets using (8) #14 x 1-1/2" hex head lag screws or #10 x 2" wood screws. Make sure they go into solid bracing as per the requirements in Table 3 Section B and Figure 21(B), below the prepared Wall Thimble opening. You can drill 5/32" pilot holes. For concrete block or poured foundation use suitable fasteners. NOTE: For 5" to 7" diameters a choice of two (2) uppermost mounting holes are available.

10. Position the Support Plate to the desired distance from the wall as per the limits shown in Table 4 and Figure 19. Tighten the 4 nuts onto the threaded studs. Proceed to Step 14.

METHOD B

11. Ensure that the Wall Support is level, and secure to the wall through the pre-punched holes located on the sides of each of the support brackets using (8) #14 x 1-1/2" hex head lag screws or #10 x 1-1/2" wood screws. You can drill 5/32" pilot holes for the lag screws. Make sure they go into solid bracing as per the requirements in Table 3 Section B and Figure 21 (B) below the prepared Wall Thimble opening. For concrete block or poured foundation use suitable fasteners. NOTE: For 5" to 7" diameters a choice of two (2) uppermost mounting holes are available.

12. Place the Insulated Tee on the support Plate ensuring that the male coupler of the Tee is facing up and the flange on the top of the Support Plate slides into the female coupler (see Figures 24 & 26).

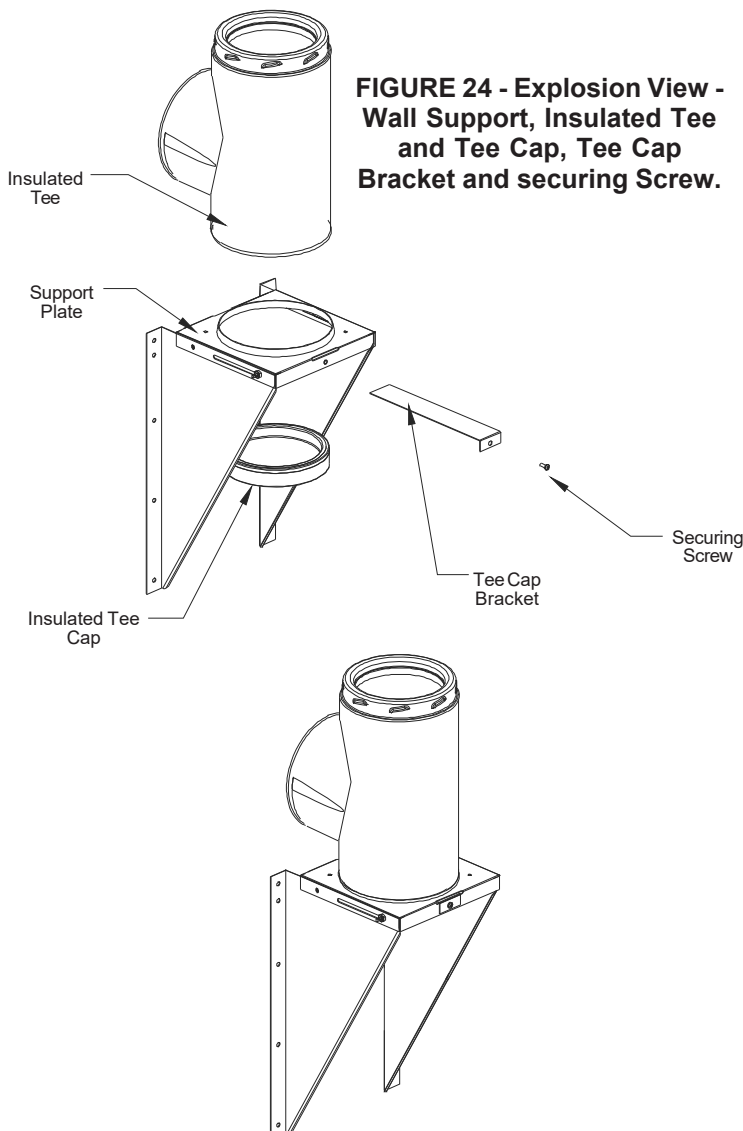

FIGURE 24 - Explosion View - Wall Support, Insulated Tee and Tee Cap, Tee Cap Bracket and securing Screw.

FIGURE 25 - Assembled Wall Support with Tee Cap Secured in Place

13. From inside the building, for an extension of the Insulated Tee, slide an appropriate Insulated Chimney Length through the Wall Thimble to the horizontal branch of the Insulated Tee. Lock securely by twisting clockwise. A Locking Band must then be installed to secure the connection. Make sure the nut and bolt are facing down to prevent any water from collecting in the Locking Band. The Tee Branch must protrude a minimum of 3" into the room. Use a longer Length if this is not met (not to exceed 24 inches).

14. Use a non-hardening high-temperature sealant (500° F) to seal around the horizontal Chimney Length where it enters through the exterior of the Wall Thimble or the concrete wall.

15. Insert and install the Insulated Tee Cap into the bottom of the Support Plate opening. To secure, slide the Tee Cap Bracket into both slots located at the front and rear of the Support Plate. Make sure the Tee Cap Bracket is beneath the Tee Cap and the other end is exiting through the slot at the back of the Support Plate. Secure in place by threading the securing screw into the nutsert located on the front of the Support Plate (see Figures 24, 25 and 26).

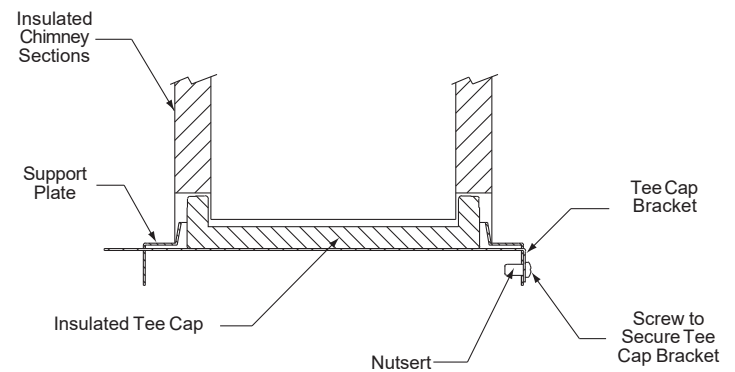

FIGURE 26 - Securing of Insulated Tee Cap

WARNING: The Insulated Tee Cap must be installed and secured in place. Failure to install could cause fire, injury or death.

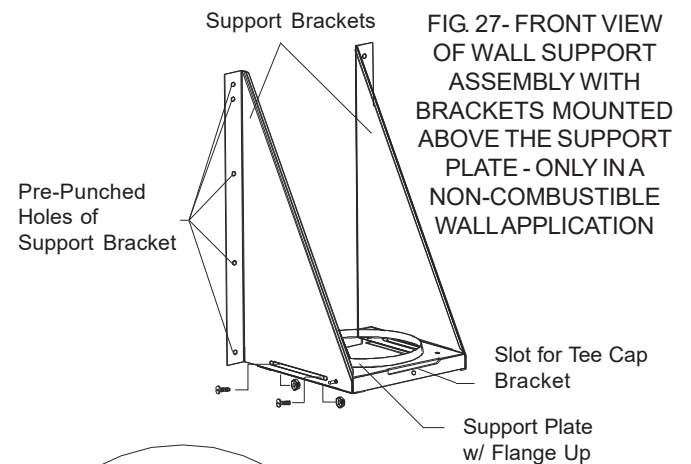

FIG. 27- FRONT VIEW OF WALL SUPPORT ASSEMBLY WITH BRACKETS MOUNTED ABOVE THE SUPPORT PLATE - ONLY IN A NON-COMBUSTIBLE WALL APPLICATION

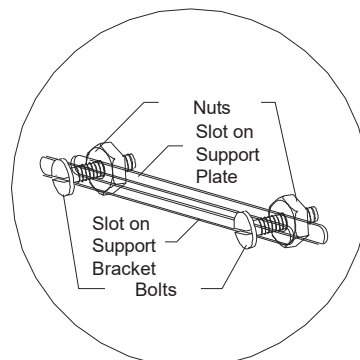

FIG. 28 - SLOT AREAS WITH BOLTS (#8 x 3/4) AND NUTS ASSEMBLY OF SUPPORT BRACKETS AND SUPPORT PLATE

NOTE: If ground clearance does not permit the installation of the Wall Support with the Support Bracket facing down, it is permissible to invert these brackets, if in a non-combustible wall application. Inverting the brackets (brackets mounted on the wall above the support plate) can be accomplished by rotating the Support Plate so that the threaded stud faces toward the front and securing each side with (2) #8 x 3/4" bolts (not supplied) through the oblong slots of the support side brackets and the support plate as per Figures 27 and 28. Secure with nuts. In this position, the range of adjustability is limited to 5" from the wall (see Table 4). Install the Insulated Tee Cap as per step 15.

16. Chimney Lengths above the Insulated Tee are simply stacked on and locked with a 1/8 clockwise turn.

Wall Band (WB) and Universal Wall Band (UWB)

17. For lateral stability of the chimney above the Wall Support, a Wall Band must be installed along an outside wall if the chimney is installed at 2" from the vertical wall and follow steps 17 to 19. Where horizontal adjustability is needed (more than 2" from the vertical wall), a Universal Wall Band can be used. For more detailed instructions see Steps 20 through 28 and Figures 30 through 33.

18. Install the first Wall Band (WB) midway up the first Chimney Length above the Insulated Tee and any additional Wall Band to be installed at 8 foot intervals above this point. For systems shorter than 8', at least one WB must be installed. Secure the Wall Band bracket to the wall using 2 6d (2") spiral nails or #8 x 2" wood screws through the pre-drilled holes (see Figure 29). For concrete or brick veneer walls, use suitable masonry fasteners or other anchoring systems.

19. Check for clearances and plumb as you fasten the Wall Bands to the wall. Use a level against the chimney sections at each support stage to keep the assembly plumb. Fasten securely the Wall Band around the chimney with the supplied nut and bolt to secure the chimney length within the band.

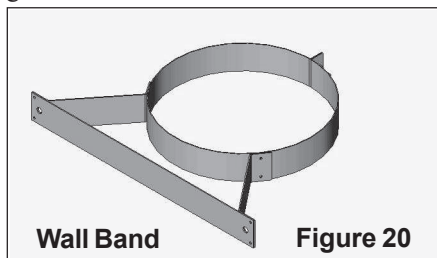

20. It is required to have a Universal Wall Band (UWB) installed every 8 feet. For systems shorter than 8', at least one Universal Wall Band (UWB) must be installed.

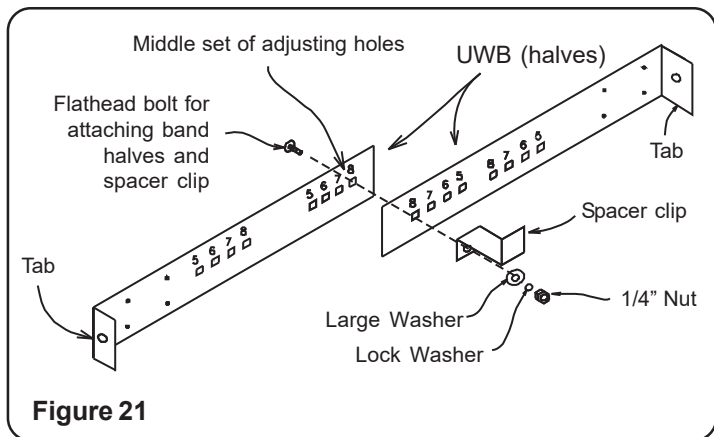

21. Place the two halves of the UWB Band as shown in Figure 21. Insert the flat head bolt through the middle set of holes in the band halves marked with the corresponding pipe diameter of the chimney being installed. (Ex. - for a 6" chimney, place the flathead bolts through the holes marked 6). The bolt should pass through the band halves with the tabs oriented outward (See Figure 30).

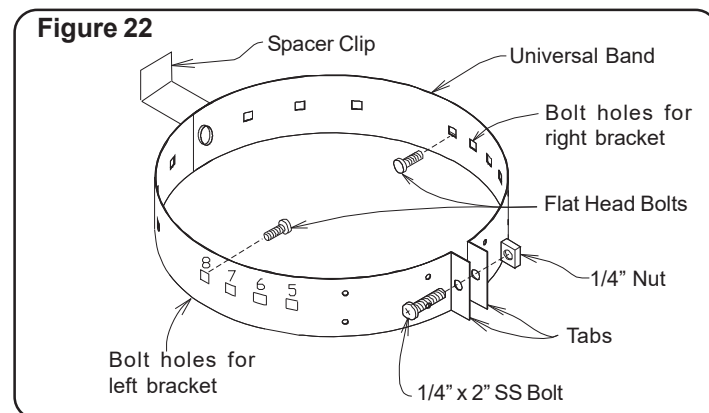

22. Place the Spacer Clip on the bolt used in the middle of the assembly and secure with washers and nut (See Figure 30).

23. Form the Band into a ring and loosely connect tabs using the 1/4" x 2" nut and bolt (See Figure 31).

24. Place the Band between the left and right brackets with the Spacer Clip and Tabs oriented as shown (See Figure 32).

25. Attach the band to the wall brackets using 2 flat head bolts (1 per bracket) and nuts. The bolts should pass through the holes corresponding to the pipe diameter and through the slots of the brackets. These slots allow for horizontal adjustment of the pipe from the wall (See Figure 32).

26. Determine the location at which the assembly will be installed. (Make sure the wall to which the brackets will be attached is structurally sound, capable of providing adequate anchoring capacity for lag bolts).

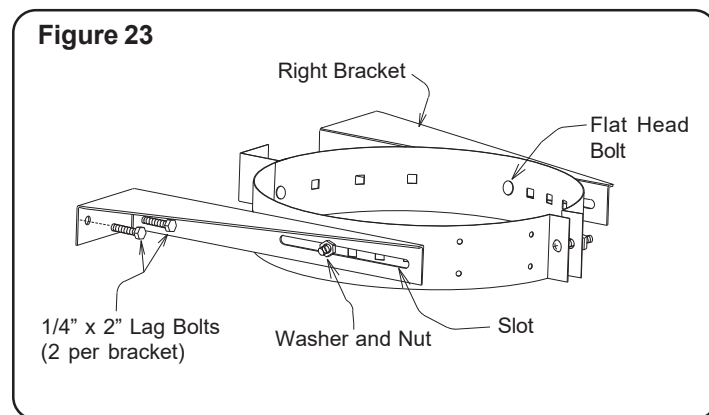

27. Level the brackets and drill pilot holes in the wall using the mounting holes in the brackets as a template. Drill 1 hole in the wall for each bracket. Secure brackets to wall using 1/4" x 2" lag bolts (see Figures 32 & 33). Use a level against the chimney sections at each support stage to keep the assembly plumb.

28. Place a length of chimney within the assembly and tighten the tabs around the chimney using the supplied 1/4" x 2" bolt to secure the chimney length within the band (See Figure 33).

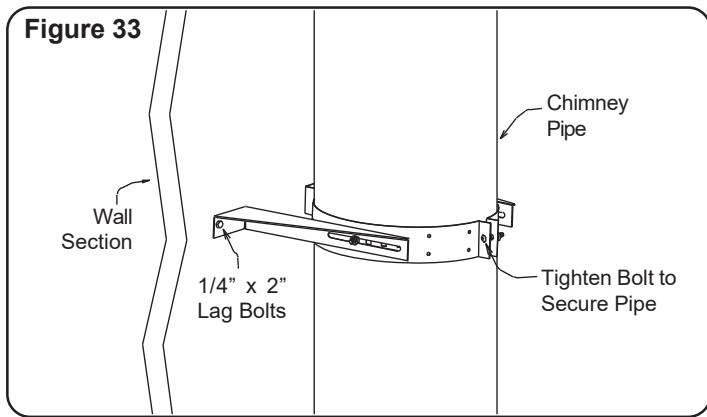

29. If the chimney penetrates an eave or overhang (soffit) cut an opening with 2" clearance all around. To find the exact spot where the chimney will pass through the eaves, drop a plumb line from the underside of the eaves to the outer edge of the leveled chimney. Mark 5 or 6 points to give an outline of the hole. Remember that the hole will need 2" clearance to the chimney surface. Install an Attic Insulation Shield if space permits on the under side of the overhang. If it is not possible, the overhang area can be enclosed and a Rafter Radiation Shield installed at the roof level and a Finishing Plate on the underside of the soffit. If the Attic is open to the overhang, close off the access with suitable building materials ensuring that a 2" air space clearance is maintained. From above, install the Roof Flashing and Storm Collar by following the Roof Flashing section in these instructions. If the overhang is not deep enough to allow the chimney to be fully installed within the overhang, it will be necessary to cut into it. Ensure that a 2" air space clearance all around the chimney is respected. Framing and flashing the sides of the opening will be required. Install a Wall Band at this level.

NOTE: Interior chimneys installed with a Wall Support must use Firestop Radiation Shield (FRS) in place of Wall Bands if extending through floor/ceiling penetrations and an Attic Insulation Shield (AIS) when passing through an unoccupied attic space.

CATHEDRAL CEILING SUPPORT (CCS)

To complete a proper Cathedral Ceiling Support installation, the following parts are required:

- Cathedral Ceiling Support (CCS): For sloped or angled ceiling.
- Stove Pipe Adaptor (ASE): Transition from chimney to flue pipe.
- Roof Flashing Assembly: Required when the chimney penetrates
- Suitable lengths of chimney: The chimney diameter should be sized to suit the appliance.
- Rain Cap: Standard or Deluxe model

The SuperVent/SuperPro Cathedral Ceiling Support will support a total of 38 feet of chimney of which 15 feet of chimney can be suspended below the support. The Cathedral Ceiling Support is screwed or nailed into framing installed between the roof rafters.

1. After framing in your opening to the dimensions specified in Table 1 found in the Framing Details section (measured in the horizontal plane), slide the Cathedral Support box into the framed opening.

2. Once the box is at the desired height, ensure the box is level and nail the box to the framing using four 2" spiral nails or #8 x1-1/2" wood screws per side. The excess material sticking above the roof can either be trimmed off before attaching the box to the framing or, after it is installed the corners can be cut and the excess material folded down onto the roof deck.

3. Install the Support Band on the chimney length at the desired position by tightening the draw band bolt and by screwing four stainless steel sheet metal screws through the draw band and into the outer casing.

NOTE: To reduce cold air infiltration into the dwelling you can install the optional Universal Shielding Insulation (JUSI) into the Cathedral Support. See separate installation instructions packaged with the JUSI.

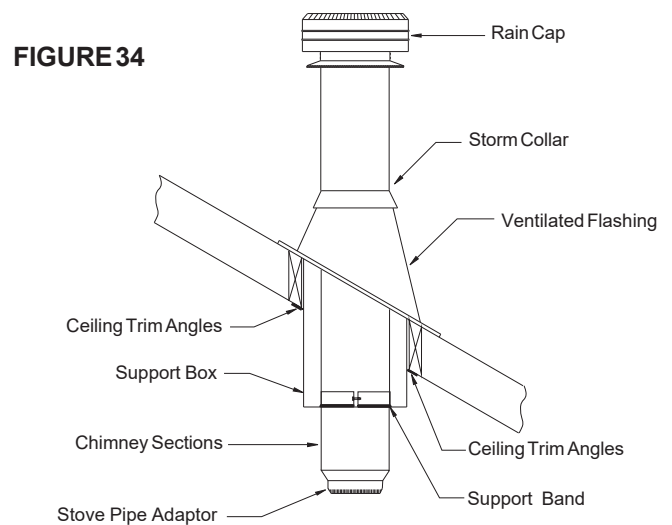

FIGURE 34

Cathedral Ceiling Support Installation

4. Lower the chimney length down through the opening in the bottom of the support so that the Support Band makes contact with the bottom of the Support Box. (See Figure 34).

NOTE: The male coupler of each chimney length must be up. The bottom chimney length(s) must protrude into the living space so that proper clearances are maintained from the stove pipe connector to the lower side of the ceiling. Refer to Chart 3 on page 22 at the back of these instructions for proper clearances. Do not offset the chimney below the Cathedral Support. **NOTE:** A minimum of 1" of the insulated chimney length must protrude below the Cathedral Support Box for stability.

5. Install additional chimney sections and lock together by turning clockwise until the two sections lock together tightly. Continue in this manner until the required height above the roof is achieved. **NOTE:** Unlike normal inside installation, a cathedral installation provides only one support point for the chimney. This limited support can allow the chimney to sway slightly or vibrate in high winds. It is advisable to install additional lateral support if the chimney extends more than 3 feet out of the roof.

6. Chimney sections (15 ft max.) installed below the Cathedral Ceiling Support are locked together from below by turning clockwise until tightly locked together with each joint being secured by a Locking Band. These lengths can be painted to match the connector pipe with a high temperature heat resistant paint. To improve adhesion to the chimney, degrease, clean, prime before painting. Follow the paint manufacturer's instructions.

7. 4 painted ceiling trim angles (2 short & 2 long) are supplied with fastening screws to finish off the Support Box at the ceiling level. The 2 long pieces are trimmed off to match the pitch of the ceiling.

RAFTER RADIATION SHIELD (RRS)

A Rafter Radiation Shield (RRS) must be installed where the chimney is enclosed immediately below the roof line as shown in figure 26. An example of this is when the attic space of a house is being used as living space (ie. bedroom, guestroom etc.). It must also be installed when height restrictions will not allow the use of the Attic Insulation Shield (AIS) and the chimney has been enclosed with an enclosure around the chimney.

Attach the support brackets to the shield (through one of the three pre-punched holes) such that once the shield is installed, the shield protects both the upper and lower parts of the roof joist framing (See figures 35 & 39).

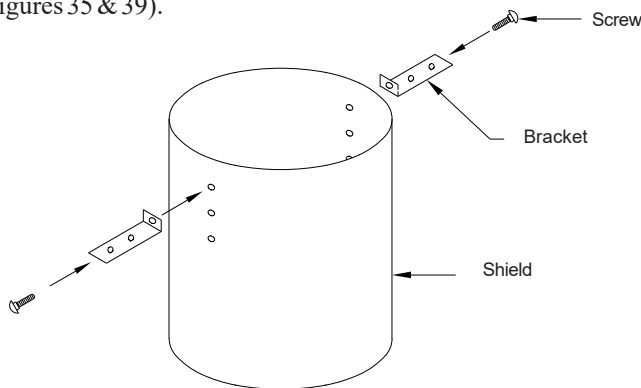

FIGURE 35 Rafter Radiation Shield Assembly

ROOF SUPPORT (RS)

The Roof Support may be used on a floor, ceiling or roof and adjusts to any roof pitch. It may be used above an offset to support the offset or as a supplementary support when the chimney height exceeds that of the primary support. It will also provide additional support for a Cathedral Ceiling installation when more than 3 feet is above the roof.

The Roof Support will support a total height of 50 feet of chimney sections of which 20 feet may be suspended beneath it. All chimney sections below the support must be secured with Locking Bands.

The Roof Support is mounted directly on the roof sheathing with

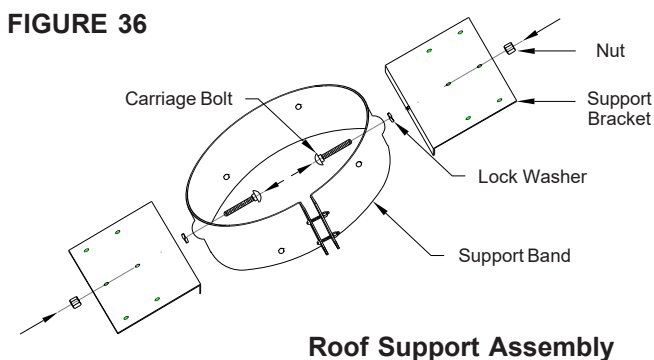

Roof Support Assembly

its feet (support bracket) resting over rafters or a framed opening to form a solid base. Frame a rectangular roof opening to provide a 2" minimum air space clearance from combustible materials. The framing dimension is measured in the horizontal plane.

Attach the support brackets to the support band with the 1/2" nuts, bolts and lock washers. The lock washer is placed between the band and support bracket to provide proper spacing as shown in Figure 27.

Slide the Roof Support down over the chimney section until the support brackets rest on the roof or floor. Use a level against or on top of the Chimney Length to ensure that the chimney is plumb prior to the final position of the support brackets. Tighten the support band around the chimney with the nuts and bolts supplied, then secure the collar by screwing the 6 supplied sheet metal screws through the holes in the support band and into the chimney casing.

Center the chimney in the joist or rafter opening (ensure that the 2" required air space clearance is met) and nail or screw the Roof Support to the roof or floor using the 12 x 3-1/2" spiral nails supplied or 12 #8 x 2" wood screws into a solid base.

Install additional Chimney Sections and lock together by turning clockwise until the two sections lock together tightly - continue in this manner until the desired height is achieved. The use of Locking Bands on all Chimney Lengths above the roof is highly recommended for added safety and stability when exposed to windy conditions.

NOTE: The male coupler of each chimney length must point up.

ROOF FLASHING

Ensure that you have the proper Roof Flashing by checking your roof pitch using a level and two rulers (see fig. 37) or by using a roof pitch card.

The AAF Roof Flashing is for roof pitches from 0/12 to 6/12.

The AF2 Roof Flashing is for roof pitches from 6/12 to 12/12.

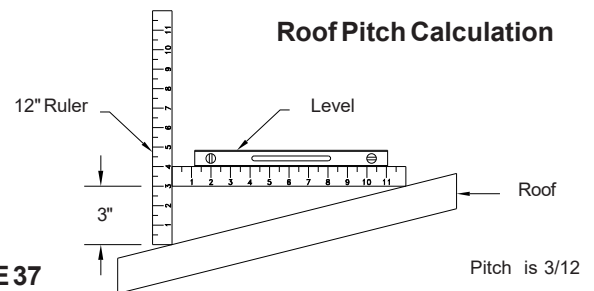

FIGURE 37

Find the centre of the opening by dropping a plumb bob from the inside of the roof sheathing to the centre of the leveled chimney length below. Do the same to find the outline of the required opening to the edge of the hole in the ceiling below. By moving the plumb bob around the edge of the opening below (which includes the required clearance) mark several points forming the outline of the hole on the underside of the roof sheathing. Remember: these measurements are in the horizontal plane. Drill pilot holes following the marked outline.

Once you have marked and located the area where the chimney will come through the roof, center, position and prepare the roof area by removing shingles, shingle nails and cutting of the roofing material. Be careful when lifting roof shingles so they do not become damaged as they may be old or if the installation is done during cold weather. Frame the opening to suit the pitch of the roof and allowing for a 2" clearance to the chimney on all four (4) sides. This is done before extending the chimney above the roof.

Slide the top edge (nearest the roof peak) of the Flashing under the roof shingles. At least half of the Flashing should be UNDER the shingles and the bottom edge OVER the shingles to provide a watershed. Trimming off the shingles may be necessary around the cone of the Flashing for a better fit. Do not nail the flashing to the roof yet as adjustments may be required.

Assemble Chimney Sections through the roof opening and Flashing. Ensure that all sections are locked together by turning clockwise until the sections lock tightly. Install Locking Bands to secure the chimney sections. Fasten the flashing with 2 screws or nails. Before committing to a final position of the Flashing and chimney, ensure the entire Chimney system is level and plumb and the required 2" air space clearance is maintained from all combustible material before permanently nailing and sealing the Flashing to the roof.

Nail the Flashing to the roof deck (also under the shingles) along the upper edge and down each side with 12 nails with neoprene washers or cover the nails with a suitable non hardening waterproof caulking. Seal the shingles to the plate in the same manner. As a precaution, you may apply a bead of caulking along all seams of the Flashing.

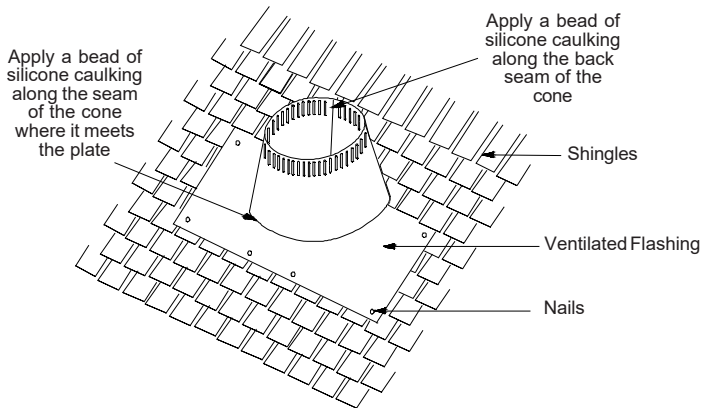

FIGURE 38 Roof Flashing Installation

Wrap the Storm Collar around the chimney above the Flashing. Secure the ends together loosely with the nut and bolt supplied.

Apply a non-hardening high temperature silicone caulking just above the top of the Flashing cone on the chimney casing. Slide the collar down the chimney until it contacts the Flashing and the caulking. Tighten the nut and bolt and apply additional caulking above the Storm Collar as required. After the installation check to ensure that the ventilation slots are not obstructed (See Figure 38).

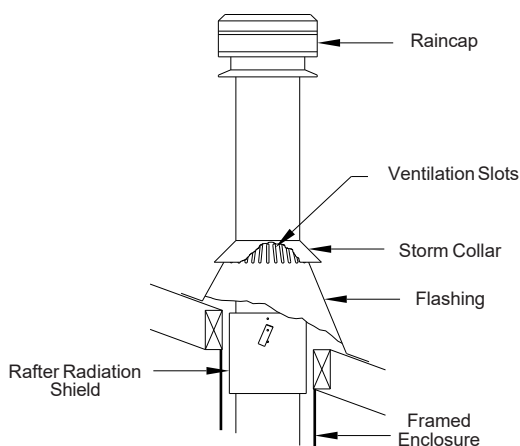

FIGURE 39 Storm Collar/Flashing Installation

WARNING: DO NOT BLOCK THE VENTILATION SLOTS ON THE FLASHING.

NOTE: A Rubber Boot Flashing Kit (URBFK) is available as an option for passing through a corrugated or metal roof. See separate instructions packaged with the Rubber Boot Flashing Kit. On metal or steep roofs, it is recommended that an ice deflector or chimney cricket fabricated from heavy-gauge galvanized steel be installed. This will protect the Chimney and the Flashing by routing the snow load and ice around the chimney.

if the chimney, Flashing and Storm Collar may be painted with a heat resistant rust proofing paint when enclosing of the chimney is not possible or if exposed to wind driven ocean spray. Salty humid air causes metal to corrode faster than air with normal humidity. This will extend its life and improve the appearance and could match the roof shingles. To improve adhesion to the SuperVent/SuperPro Chimney, degrease, clean and prime before painting. Follow the paint manufacturer's instructions.

Continue adding Chimney Lengths until the proper height is achieved as per Figure 1 requirements (also Chart 2 on page 22 of these instructions). Install Locking Bands at all chimney joints above the roof line for added security. Install the Rain Cap and lock it in place by turning clockwise until snug.

ROOF GUY INSTALLATION (JURGK-1)

If the chimney extends 5 feet or more above the roof line (measured from the upper slope), a Roof Guy Kit is required. The Roof Guy Kit provide lateral support to the chimney above the roof line. The kit contains Telescoping Legs, draw band, Roof angle Brackets and hardware package.

The Roof Guy Kit accommodates most models of chimneys with outer diameters ranging from 7" through 13".

NOTE: Different holes combination can be selected as required.

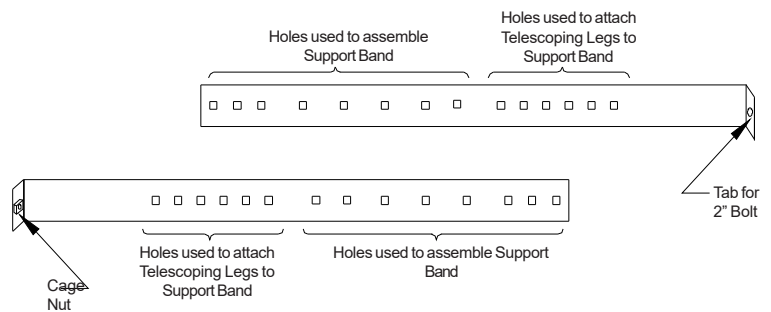

Figure 28 Support Band Holes Identifier

To Install:

- A. Measure the outside (OD) diameter of your chimney.
- B. From the single row of holes (see Figures 28 and 29), select the hole in each half that corresponds to the outside diameter identified with the chimney being installed. Place the two halves together. Insert an elevator bolt through the chosen holes (Ex - for a 10" OD chimney, place the elevator bolt through the holes identified for 10" OD). The elevator bolt should be oriented as shown in Figure 30. Secure the center bolt with washers and 1/4" flanged nut (see Figure 30). NOTE: On smaller diameter chimneys the excess band material can be cut off.

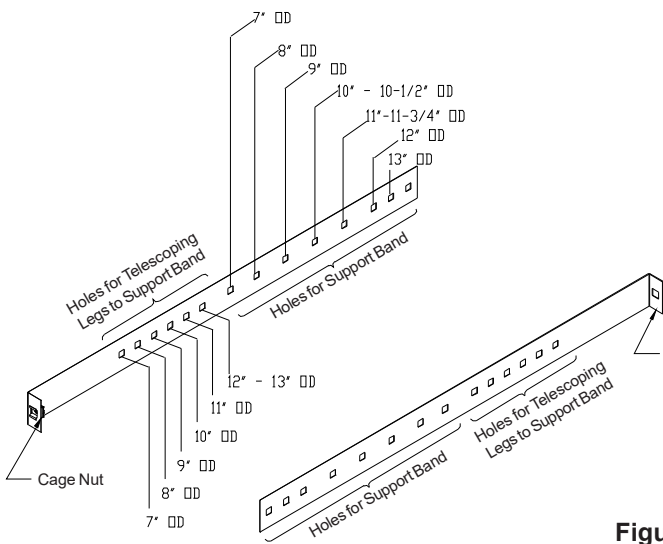

Figure 29
Assembly of Universal Support Band (2 Halves)

Assembly of Support Band:

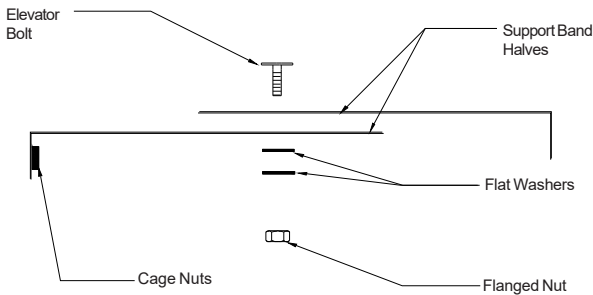

Figure 30 Topview assembly of Support Band - Elevator Bolt, Washers and Nut

C. Form the band into a circle (see Figure 31) and loosely connect tabs using the supplied 2" bolt into the cage nut located on one of the two formed tabs.

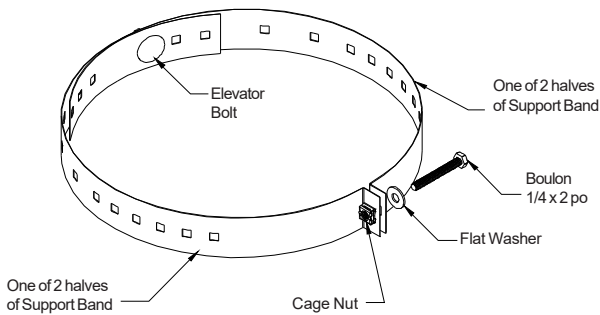

Figure 31 Universal Support Band formed into a circle

D. Select the hole in each half that corresponds to the OD of the chimney. Insert an elevator bolt in each of the holes (1 per side).

E. Position the Support Band approximately two thirds of the way up the chimney height (see Figure 35). The preferred location is next to a joint, immediately above or below a Locking Band. Secure Support Band by tightening the 2" bolt. NOTE: Only one chimney joint should be above a Roof Guy Kit. An additional Roof Brace Kit may be required for taller systems.

F. Assemble the telescoping legs by sliding the supplied hose clamp over larger diameter leg and then inserting smaller diameter leg into larger diameter leg. Temporarily hold legs together by tightening the hose clamp over the cut section of larger diameter leg (see Figure 32). Repeat for the other telescoping leg assembly.

G. Place a flat washer on the elevator bolts and attach the angled end of each of the telescoping legs to the 2 elevator bolts on the Support Band with washer and nut (see Figure 33).

Assembly of Telescoping Legs with Hose Clamp
Figure 32

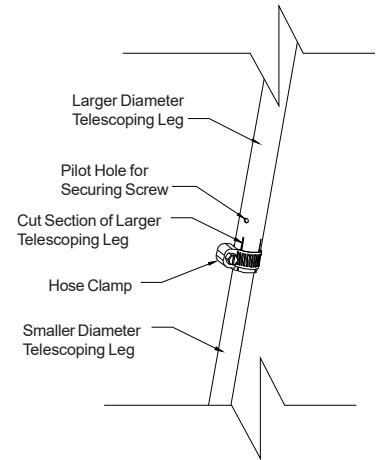

H. Attach the other end of each telescoping leg assembly to an Angle Bracket using one (1) 1/4-20 X 1" bolt and nut (see Figure 34).

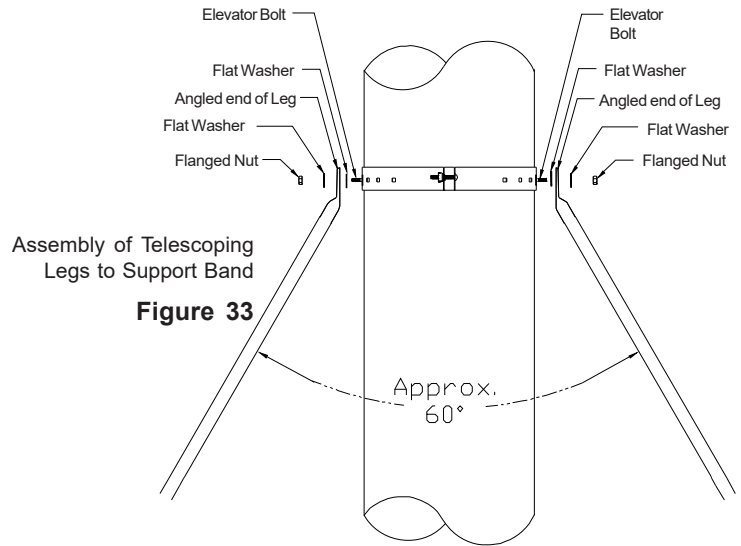

Assembly of Telescoping Legs to Support Band
Figure 33

I. Determine the location of the two Angle Brackets on the roof structure. Ensure the fasteners are into rafters or framing and not just roof sheathing. Secure the Angle Brackets to the roof structure using two (2) 1/4 X 2" lag screws per brackets (see Figure 34). Apply a thin layer of caulking under the angle bracket (before securing in place) as well as over the lag screw heads.

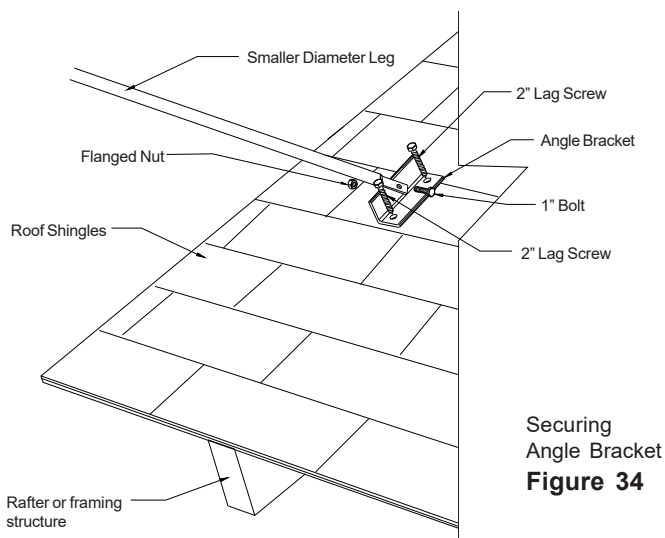

Securing
Angle Bracket
Figure 34

J. Make sure the chimney is level and plumb. Check all required dimensions and angles, adjust if necessary. For added security, lock legs in place by using 1/8" x 1/2" stainless steel self tapping screw (supplied) through the pilot holes found near the hose clamps (Figure 32).

K. The two telescoping legs should form an angle of about 60° to give support to the chimney in all directions. The angle of the telescoping legs should be approximately 45° from vertical when fastened to the roof (see Figures 33 & 35).

NOTE: Do periodic inspections of all fasteners including the hose clamps as high winds can cause the chimney system above the roof to vibrate and in time loosen some of the fasteners.

MODEL JSC/SPR ADAPTER PLATE

The Adapter Plate may be used for adapting the JSC/SPR chimney to a "Listed" Factory-Built Fireplace certified for use with Model JSC/SPR.

NOTE: It is of the utmost importance that the Anchor Plate be installed in accordance with the manufacturers installation instructions supplied with the "listed" Factory-Built Fireplace.

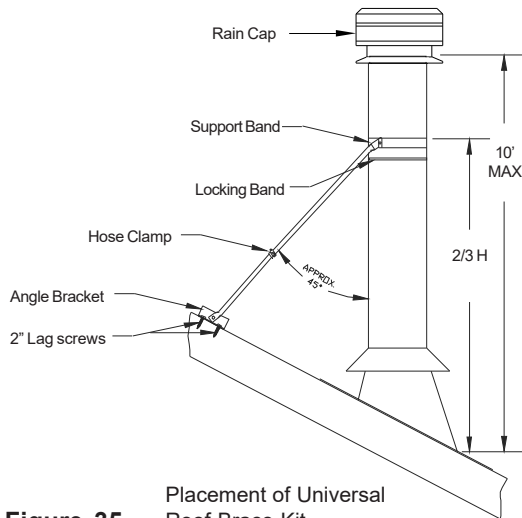

Figure 35 Placement of Universal
Roof Brace Kit

MAINTENANCE AND CLEANING OF CHIMNEY:

“Creosote and Soot - Formation and Need for Removal”

The need for chimney maintenance depends on the kind of appliance and how it is operated. Gas and oil-burning appliances need very little, but wood-burning appliances may need a great deal of chimney maintenance.

How you burn wood in your stove or fireplace directly affects the formation of creosote. Use more dry kindling and paper first to warm up the chimney system to a temperature between 350° to 500° F. Burn hot, bright fires and fire each load hot. It is important to load your appliance properly and to avoid smoldering fires. Fast, effective start-ups are important, as is the moisture content of the wood being burned. If your wood is not completely seasoned, split your wood in smaller pieces instead of larger ones. Ideally, the moisture content of your firewood should be between 18 to 22%. A good investment in assisting you in monitoring your system is a surface thermometer for single wall stove pipe or a probe thermometer for double wall stove pipe. Ensure that only low sulphur content coal (1% or less) such as anthracite is burned.

When wood is burned slowly, it produces tar and other organic vapors, which combine with expelled moisture to form creosote. The creosote vapors condense in the relatively cool chimney flue of a slow-burning fire. As a result, creosote residue accumulates on the flue lining. When ignited, this creosote creates a chimney fire with extremely high temperatures.

With a new installation, the chimney should be inspected frequently (every 2 wks) to determine the rate of creosote formation. When familiar with the appliance and chimney characteristics, the chimney should be inspected at least once every 2 months during the heating season to determine if a creosote or soot build-up has occurred. Check spark arrestor screens at least every 2 to 4 weeks. If the spark arrestor becomes clogged with creosote, it should be cleaned or replaced.

If creosote or soot has accumulated, it should be removed to reduce the risk of a chimney fire. Depending on the rate of build-up (as little as 1/16") and as you learn what is going on in the chimney, you can adjust your cleaning schedule accordingly. Every chimney flue and flue pipe shall be inspected annually and cleaned as often as may be necessary to keep the chimney and flue pipe free from dangerous accumulation of combustible deposits.

Chimney and flue pipe are particularly susceptible to off-season condensation. The incomplete combustion of wood produces acids which, when combined with moisture, are corrosive. During the heating season, corrosion tends not to occur because the heat in the system evaporates the condensation of any water vapour that may be formed.

Warm, moist air during the summer months passes slowly through the heating system. It makes any remaining ash or creosote moist and soggy. Corrosion of steel occurs where these deposits remain.

Off-season corrosion can be reduced considerably if the system is thoroughly cleaned after the last fire of the heating season. Where coal is burned, the system must be thoroughly cleaned within 48 hours of shutting down the system for the season and all soot be removed from the chimney system. This should be the most careful cleaning the system receives all year. Air inlets should be closed and

sealed if necessary to prevent the constant flow of air through the system.

Contact a professional certified chimney sweep for chimney cleaning services and advice if you have any doubts about your ability to clean your chimney system or if the task is too large. To visually inspect the chimney, remove the Rain Cap by simply using the twist-lock feature. Care should be taken not to disengage any lower chimney sections. This will permit the insertion of a flashlight for inspection and a properly sized plastic chimney cleaning brush. A metal brush may scratch the liner and lead to premature corrosion.

The Insulated Tee Cap (if so equipped) can be removed by twisting anti clockwise or by removing the securing bolt and Tee Cap Bracket to inspect or clean from the bottom. Be sure to replace the Tee Cap or Insulated Tee Cap, Tee Cap Bracket/Securing Bolt and Rain Cap when you are finished inspecting/cleaning the chimney.

If chemical cleaner is used to assist in the cleaning of your SuperVent/SuperPro chimney, make sure it is a product which is non corrosive. It does not replace the need for a mechanical cleaning. The optimal method for cleaning a chimney is by a mechanical brushing of the chimney in conjunction with a complete evaluation of the system by a certified chimney sweep.

CHIMNEY FIRES AND WHAT TO DO ABOUT THEM

Your SuperVent/SuperPro is not intended or designed for use as a combustion or fire chamber. It is very easy to overfire your woodburning appliance with kindling, scrap lumber, brush or any fast burning fuel. This can produce flames and high temperatures all the way up the chimney, and may cause chimney damage. The following materials should not be burned in your woodburning appliance: pressure treated lumber, rail road ties, salt water driftwood or plastic. Burning such materials may lead to severe corrosion of the appliance and the chimney system.

If you see your appliance or the stove pipe glowing red, you are risking chimney damage, or a fire. The creosote may be burning inside the chimney. If you see flames coming out the top, you are either overfiring or there is a chimney fire.

If the fire in your appliance has gotten out of control, or if you suspect a chimney fire for any reason, follow these steps:

1. Immediately close all dampers and/or air entrance openings to your appliance. This includes doors on Franklin type stoves. Block off fireplace openings.
2. Alert your family to the possible danger.
3. Inspect your appliance and chimney surroundings for possible fire. If in doubt, alert your Fire Department.
4. Do not continue to use your appliance until it and your chimney have been thoroughly inspected. Overheating can cause metal parts to expand, buckle and crack. If you are not certain, have a certified wood technician or certified chimney sweep disassemble all parts so they can be inspected and replaced.
5. Do not use salt or water on the fire in your appliance. Salt is corrosive and water will cause a dangerous steam explosion. You might be able to control the fire by using ashes, sand or baking soda. Baking soda is an ingredient used for dry chemical fire extinguishers.
6. After a chimney fire, when it is safe to do so, check internal locations such as the attic and under the roof and keep watching for two or three hours. There may be delayed smoldering and subsequent ignition, even if the fire inside the chimney has been controlled.

WARNING:

DO NOT USE FUEL MATERIALS CORROSIVE TO THE CHIMNEY LINER SUCH AS DRIFTWOOD, PLASTICS, CHEMICALLY TREATED WOOD, ETC.

CHART 1 - OFFSET CHIMNEY INSTALLATION

It may be necessary to offset the chimney in order to clear a joist or an obstacle. The three (3) charts below will assist you in selecting the proper combination of elbow angle and chimney length(s) that will provide the necessary degree of offset within an available height.

1. Select the column with the proper chimney diameter of your system.

2. Determine the distance of the offset required by dropping a plumb line for an accurate measurement. The offset is measured at the chimney centre line as per the "A" Offset measurement in the diagram below.

3. On the chart, find the predetermined distance (under the "A" column) required for the 15° elbow. For greater offset, use the 30° or 45° offset charts. NOTE: The 45° elbows may be used **ONLY** in Canada.

4. After finding the offset, look at the "B" (height) measurement in the chart to find the specified height. The appropriate "chimney lengths" required in between elbows is found in the left hand side column of each charts.

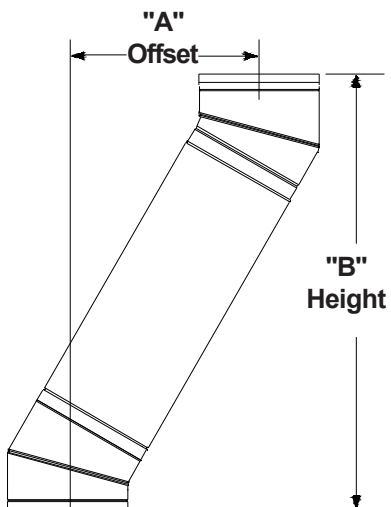

NOTE:

• SuperVent/SuperPro chimneys are limited to offsets not exceeding 30 degrees. Combining offsets for greater angle is not permitted. **The 45° elbows may be used ONLY in Canada.**

• Never install an elbow in a joist area. Chimney sections must pass vertically through framed joist areas.

• Locking Bands must be use at all chimney joints.

• Each elbow support will support 15 feet of chimney.

• The maximum length of chimney allowed between elbows is 6 feet.

Chimney Lengths	5" Diameter		6" Diameter		7" Diameter		8" Diameter	
	A	B	A	B	A	B	A	B
none	1-1/2"	9"	1-1/8"	10"	1-1/8"	10-1/4"	1-1/4"	10-3/8"
6"	2-1/8"	13-1/2"	2-3/8"	14-1/4"	2-3/8"	15"	2-1/2"	15-5/8"
12"	4"	19-1/8"	4"	20-1/2"	4-1/16"	20-3/4"	4-1/8"	21"
18"	5-1/2"	25"	5-1/2"	26-1/4"	5-1/2"	26-1/2"	5-5/8"	26-3/4"
24"	7-1/2"	30-1/2"	7"	32"	7-1/16"	32-1/4"	7-1/8"	32-1/2"
36"	10-1/8"	42"	10-1/4"	43-5/8"	10-1/4"	44"	10-1/4"	44-1/8"
6" + 36"	11-1/4"	48-1/4"	11-3/8"	48-3/8"	11-1/2"	48-5/8"	11-1/2"	48-7/8"
12" + 36"	12-3/4"	54"	13"	54-1/8"	13"	54-3/8"	13"	54-5/8"
18" + 36"	14-3/8"	59-3/4"	14-1/2"	60"	14-1/2"	60-1/8"	14-5/8"	60-3/8"
24" + 36"	16"	65-1/2"	16-1/8"	65-3/4"	16-1/8"	66"	16-1/8"	66-1/4"
12"+24"+36"	19"	76-1/4"	19"	76-1/4"	19"	76-1/2"	19"	76-3/4"

Chimney Lengths	5" Diameter		6" Diameter		7" Diameter		8" Diameter	
	A	B	A	B	A	B	A	B
None	3"	10"	2-3/4"	11-5/8"	3-1/8"	13"	3-1/2"	14-1/2"
6"	5-1/4"	14"	5-1/4"	15-7/8"	5-5/8"	17-1/4"	6"	18-3/8"
12"	9"	19-1/4"	8-1/4"	21"	8-5/8"	22-3/8"	9"	24"
18"	11-1/4"	24-1/2"	11-1/4"	26-1/4"	11-5/8"	27-5/8"	12"	29-1/8"
24"	14-1/4"	29-3/4"	14-1/4"	31-3/8"	14-5/8"	32-7/8"	15"	32-3/8"
36"	20"	39-3/4"	20-1/4"	41-7/8"	20-5/8"	43-1/4"	21"	44-3/4"
6" + 36"	21-7/8"	44-1/2"	22-5/8"	46"	23"	47-1/2"	23-1/2"	49"
12" + 36"	23-7/8"	50-1/8"	25-5/8"	51-1/4"	26"	52-5/8"	26-1/2"	54-1/8"
18" + 36"	27-1/8"	55-1/8"	28-5/8"	56-3/8"	29"	57-3/8"	29-1/2"	59-3/8"
24" + 36"	30-3/8"	60-5/8"	31-5/8"	61-5/8"	32"	63"	32"	64-1/2"
12"+24"+36"	37"	69-3/8"	37-1/8"	71"	37-1/2"	72-1/2"	38"	74"

Chimney Lengths	5" Diameter		6" Diameter		7" Diameter		8" Diameter	
	A	B	A	B	A	B	A	B
None	6"	10-1/8"	4-3/8"	12"	5-1/2"	14"	5-3/4"	15-1/8"
6"	9-1/8"	13-5/16"	7-3/4"	15-5/8"	9-3/4"	18"	9-1/2"	19-1/4"
12"	13-3/8"	17-1/2"	11-7/8"	19-3/4"	13"	21-3/4"	13"	22-1/2"
18"	17-5/8"	21-3/4"	16"	23-7/8"	17-1/4"	25-3/8"	17"	27"
24"	21-13/16"	26"	20-1/2"	27-3/4"	21-3/4"	29-7/8"	21-5/8"	31"
12" + 24"	29-5/16"	33-7/16"	23-7/8"	31-3/8"	25-5/8"	32-3/4"	24-5/8"	34-1/2"
36"	30-3/8"	34-1/2"	28-1/2"	36-7/8"	30-5/8"	38-1/8"	29-5/8"	39-7/8"
12" + 36"	37-3/4"	41-7/8"	36-1/4"	44-3/8"	38-1/8"	45-1/8"	38-1/8"	47"
18" + 36"	42"	46-3/16"	40-1/8"	49-1/4"	42-3/4"	49-1/4"	41-7/8"	51-1/2"
24" + 36"	46-1/4"	50-7/16"	47-7/8"	56-1/2"	50-1/2"	57-3/8"	49"	59-3/8"
12"+24"+36"	53-5/8"	57-7/8"	41-1/2"	45-5/8"	38-1/4"	46-1/2"	38-1/2"	48-7/8"

All measurements are in inches. Construction tolerances ± one inch.

CHART 2 - CHIMNEY HEIGHT ABOVE THE ROOF

Requirement # 1 : *The code requires that the chimney must extend at least 3 feet above the highest point of the roof that it penetrates.*

Requirement # 2 : *The chimney must also be 2 feet above any roof, wall or other obstruction within a horizontal distance of 10 feet.*

The following Chart is to assist you in determining the minimum chimney height you will require above the roof. You may need to add to this height as nearby buildings, trees and other parts of the house roof could interfere with airflow over and around the top of the chimney and affect its performance. If you think a nearby obstacle could affect draft, you might want to install one or more additional lengths.

DISTANCE FROM PEAK	PITCH OF ROOF											
	1/12	2/12	3/12	4/12	5/12	6/12	7/12	8/12	9/12	10/12	11/12	12/12
	CHIMNEY HEIGHT ABOVE ROOF (INCHES)											
10 Ft	*36	44	54	64	74	84	94	104	114	124	134	144
9 Ft	*36	42	51	60	69	78	87	96	105	114	123	132
8 Ft	*36	40	48	56	64	72	80	88	96	104	112	120
7 Ft	*36	38	45	52	59	66	73	80	87	94	101	108
6 Ft	*36	36	42	48	54	60	66	72	78	84	90	96
5 Ft	*36	*36	39	44	49	54	59	64	69	74	79	84
4 Ft	*36	*36	36	40	44	48	52	56	60	64	68	72
3 Ft	*36	*36	*36	36	39	42	45	48	51	54	57	60
2 Ft	*36	*36	*36	*36	*36	36	38	40	42	44	46	48
1 Ft	*36	*36	*36	*36	*36	*36	*36	*36	*36	*36	*36	36

* Defaulted to 36" to meet requirement #1. Both requirements (#1 and #2) must be met.

• If the chimney extends 5 feet or more above the roof, a Universal Roof Guy Kit (JURGK-1) is required.

• It is highly recommended that any lengths above the roof should have locking bands at all joints for added safety and stability. This will eliminate the risk of sections becoming undone below the roof line when the Rain Cap is removed when inspections and cleaning of the system is being done.

CHART 3 - Connector Pipe Clearance below Cathedral Support

1. Identify the type of connector pipe you will be installing, single wall (requires 18" clearance to combustibles) or Selkirk's Double Wall Stove Pipe (model DSP) which requires 6" clearance to combustibles.

2. Determine the amount of the exposed Cathedral Support that will be projecting into the room as per the "X" in the diagram on the bottom left.

3. Select the pitch of your sloped ceiling from the chart below.

4. Select the measurement from the chart below where the pitch of the sloped ceiling intersects with the exposed Cathedral Support row selection. This will determine the measurement of insulated chimney required below the Cathedral Support as per the "Y" in the diagram on the left. The minimum of insulated chimney below the Cathedral Support is 1 inch. This minimum is required for stability of the system.

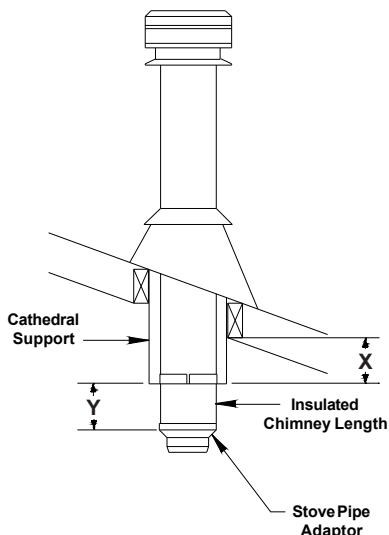

CONNECTOR PIPE CLEARANCE REQUIREMENTS FROM SLOPED CEILING													
EXPOSED CATHEDRAL SUPPORT INTO ROOM		PITCH OF SLOPED CEILING											
		1/12	2/12	3/12	4/12	5/12	6/12	7/12	8/12	9/12	10/12	11/12	12/12
1 Single Wall Flue Pipe	"X" measurement	"Y" MEASUREMENT - INSULATED CHIMNEY LENGTH INTO ROOM											
	Box flush to ceiling on lower end	1.5	3	4.5	6	8	9	10.5	12	13.5	15	16.5	18
	Box 1" into the room	1	2	3.5	5	7	8	9.5	11	12.5	14	15.5	17
	Box 2" into the room	1	1	2.5	4	6	7	8.5	10	11.5	13	14.5	16
	Box 3" into the room	1	1	1.5	3	5	6	7.5	9	10.5	12	13.5	15
2 DSP - Double Wall Stove Pipe	"X" measurement	"Y" MEASUREMENT - INSULATED CHIMNEY LENGTH INTO ROOM											
	Box flush to ceiling on lower end	1	1	1.5	2	2.5	3	3.5	4	4.5	5	5.5	6
	Box 1" into the room	1	1	1	1	1.5	2	2.5	3	3.5	4	4.5	5
	Box 2" into the room	1	1	1	1	1	1	1.5	2	2.5	3	3.5	4
	Box 3" into the room	1	1	1	1	1	1	1	1	1.5	2	2.5	3

¹ Single Wall Flue Pipe requires 18" clearance from any combustible materials.

² DSP Double Wall Stove Pipe requires 6" clearance from any combustible materials.

All measurements are in inches.

REPLACEMENT PARTS LIST

DESCRIPTION	SUPERPRO PART N°.	SUPERVENT PART N°.
48" Chimney Length	SPR*L48	N/A
36" Chimney Length	SPR*L36	JSC*SA3
24" Chimney Length	SPR*L24	JSC*SA2
18" Chimney Length	SPR*L18	JSC*SA18
12" Chimney Length	SPR*L12	JSC*SA1
6" Chimney Length	SPR*L6	JSC*SA6
12" Adjustable Length	SPR*AL	JSC*AL
Tee with Plug	SPR*ITP	JSC*SITS
Insulated Tee Cap	J*1TPI	J*1TPI
15° Elbow Kit	SPR*EL15K	JSC*SEK
30° Elbow Kit	SPR*EL30K	JSC*SE3K
45° Elbow Kit	SPR*EL45K	JSC*SE4K
Ceiling Support	SPR*CSB	JSC*DCS
Wall Support (Kit)	JSC*AWS	JSC*AWS
Intermediate Wall Support	JSC*AIWS	JSC*AIWS
Wall Support	JSC*WS	JSC*WS
Cathedral Ceiling Support	SPR*CCSB	JSC*CCSB
Roof Support	JSC*RS	JSC*RS
Elbow Support	JSC*ES	JSC*ES
Locking Band	SPR*SLB	JSC*SLB
Stove Pipe Adaptor	JSC*ASE	JSC*ASE
Wall Thimble	SPR*WTB	JSC*WT
Trim Collar	J*TC	J*TC
Wall Band	JSC*WB	JSC*WB
Universal Wall Band	JSC*UWB	JSC*UWB
Adjustable Ceiling Plate	JSC*CT	JSC*CT
Universal Roof Guy Kit	JURGK-1	JURGK-1
Adaptor Plate	JSC*AP	JSC*AP
Firestop Joist Shield	JSC*FRS	JSC*FRS
Attic Insulation Shield Rafter	JSC*AIS	JSC*AIS
Radiation Shield Finishing Plate	JSC*RRS J*FP	JSC*RRS J*FP
Deluxe Rain Cap	SPR*DRC	JSC*DRC
Standard Rain Cap	N/A	JSC*RC
Spark Arrestor	JSC*SPAR	JSC*SPAR
Flat Roof Flashing	JSC*ATC	JSC*ATC
1/12-6/12 Roof Flashing	JSC*AAF	JSC*AAF
6/12-12/12 Roof Flashing	JSC*AF2	JSC*AF2
Rubber Boot Flashing Kit	URBFK1	URBFK1
Storm Collar	JSC*SC	JSC*SC
Universal Shielding Insulation	JUSI	JUSI
Snow Splitter	2001922	N/A

* Specify chimney size

Model SuperVent (JSC/FC) and SuperPro (SPR) chimneys and components are interchangeable with one another. Both are listed to UL103 Type HT in the US and to CAN/ULC-S604 in Canada.

Leave with homeowner. Homeowner: Keep in a safe place for future reference.

PRODUCT INFO

CHIMNEY MODEL : **SuperVent / SuperPro**

FLUE SIZE _____

TOTAL HEIGHT _____

INSIDE INSTALLATION OUTSIDE INSTALLATION

CONNECTED TO (type of appliance):

- BOILER
- FURNACE
- LISTED FACTORY-BUILT FIREPLACE
- OTHER (specify) _____

LOCATION OF APPLIANCE:

- BASEMENT
- MAIN FLOOR
- OTHER (specify) _____

INSTALLATION DATE: _____

DEALER INFO

DEALER NAME: _____

Address: _____

City: _____

Province: _____

TECHNICIAN INFO

TECHNICIAN NAME: _____

Address: _____

City: _____

Province: _____