

ADAPTING MODEL DT TO FACTORY BUILT AND MASONRY CHIMNEYS

4DT-CCK (Factory-Built Chimney Conversion Kit)

4DT-MCK (Masonry Chimney Conversion Kit)

WARNING

Failure to follow the instructions could cause **FIRE, CARBON MONOXIDE POISONING, OR DEATH**. If you are unsure of installation requirements, call the Phone Number listed on the instructions or visit www.selkirkcorp.com

GENERAL

Two different types of direct vent conversion systems are described here. One is through an existing factory built metal chimney going through the ceiling. The other is through the wall of an existing masonry chimney. Follow the appropriate directions for your situation.

A typical direct vent conversion to a factory built metal chimney is shown in Figure 1. The concept of direct vent conversion is to connect an adapter to an Underwriters Laboratories listed 4" aluminum flex pipe for direct vent gas appliances. (Selkirk Model AFCL is an example of a UL listed flex pipe or 4" stainless steel flex pipe for Direct-Temp for Pellet Stoves applications. Selkirk Model SFCL is an example of a UL listed stainless steel flex pipe). The flex is then passed down through the center of the existing metal chimney system.

The Chimney Inlet Connector is then attached to the bottom of the flex pipe. Both the Outlet Connector and Inlet Connector are attached to the existing chimney with sheet metal screws. The appliance is then connected to the chimney with appropriate black direct vent pipe, and an adjustable length section.

A typical conversion to an existing masonry chimney is shown in Figure 6. For installation through the wall of an existing masonry chimney, a Chimney Outlet Connector and Flashing are used at the top of the masonry chimney. The flex pipe liner is connected to the adapter and is passed down the chimney and out through the masonry wall. This is attached to the Chimney Inlet Connector which in turn is attached to the masonry wall and is then connected to the direct vent pipe leading to the appliance.

CONVERSION TO A FACTORY BUILT METAL CHIMNEY

1. Remove the existing chimney cap.
2. Measure the distance from the top end of the chimney to the bottom of the ceiling support, add 3-inches to this measurement, and cut a section of flex pipe to that length (the flex should already be extended to its normal length).
3. Connect the end of the flex pipe section to the underside of the Chimney Outlet Connector you have selected, using three sheet metal screws. Refer to Figure 2.
4. Pass the flex pipe down through the center of the chimney system, and center the Outlet Connector on the top of the chimney pipe. Drill four 1/8-inch diameter holes through the adapter, and into the chimney top. Insure that you are in fact, drilling into the metal on the chimney. Install the Termination Cap onto the Outlet Connector. Refer to Figures 3 and 4.
5. Pull the flex pipe down through the ceiling support box, until it protrudes approximately 3-inches. Connect the flex pipe to the Chimney Inlet Connector by slipping it into the sleeve on the top side of the Connector. Use three sheet metal screws, to assemble these two parts.
6. Push the flex pipe back up into the ceiling support, center the Chimney Inlet Connector, and attach it to the support box, or decorative sleeve for double wall solid packed pipe, with the sheet metal screws furnished. The holes in the connector are pre-punched. Refer to Figure 5.
7. The connection between the appliance and the Chimney Inlet Connector may be completed with sections of black direct vent pipe, together with an adjustable length.

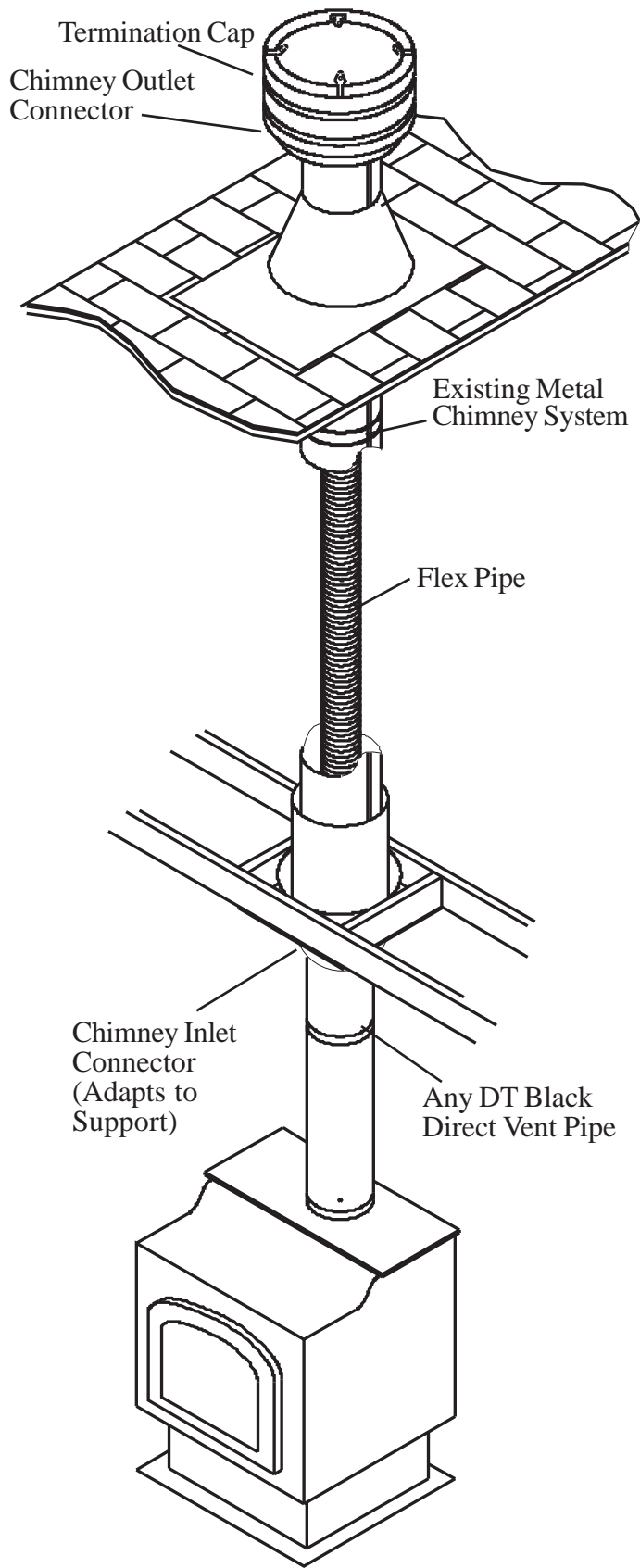

Fig 1

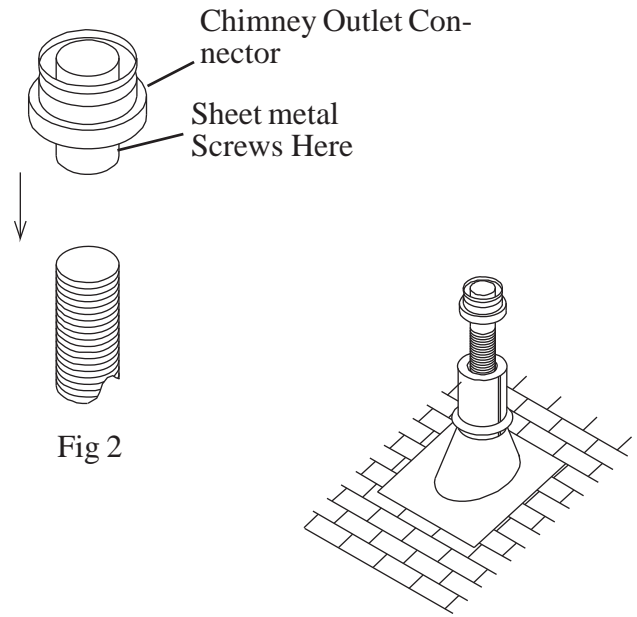

Fig 2

Fig 3

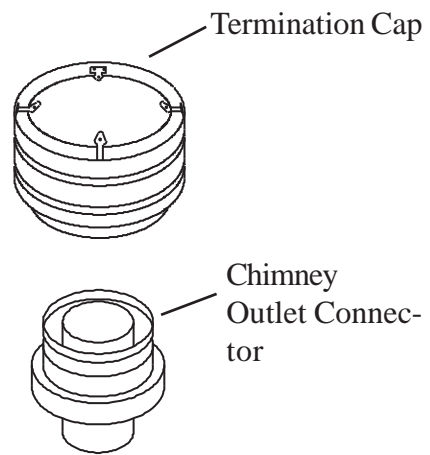

Fig 4

CONVERSION TO A MASONRY CHIMNEY

IMPORTANT: The existing masonry flue opening needs to have an area of at least 35-square inches to insure proper intake/exhaust flow.

1. Before cutting any holes, assemble the desired sections of black direct vent pipe to determine the center of the masonry penetration.

2. Once the center point of penetration has been determined, cut a 6-inch diameter hole in the masonry. Be careful, if the hole is too large, the Chimney Inlet Connector might not mount properly, and if the hole is too small, then the appliance might starve for intake air. If there is a frame wall in front of the masonry wall, cut and frame a 10" clear square opening in wall (centered around the 6" masonry opening). If there is sheet rock only (no studs) in front of the masonry, the 10" clear opening is still needed, but does not need to be framed. This allows the Chimney Inlet Connector to mount directly on the masonry and provide clearance to the combustibles. Refer to Figure 11.

3. Secure the Flashing to the top of the masonry chimney using a bead of non-hardening mastic sealer. If the Flashing is larger than the top of the chimney, then cut and fold flashing as needed to fit chimney. See Figure 7.

4. To determine the length of flex required, measure from 3" above the top of the Flashing down to the level of the opening. Add to this measurement the distance from the center of the chimney to out through the wall. Cut a piece of 4-inch flex to this length (the flex should already be extended to its nominal length).

5. Connect the 4-inch flex liner to the Chimney Outlet Connector using three sheet metal screws. Refer to Figure 2.

6. Feed the 4-inch flex liner through the Flashing into the chimney. Continue to feed the liner out through the opening in the masonry wall.

7. Secure the Chimney Outlet Connector to the Flashing. Use three sheet metal screws through the side of the adapter into the flange on the Flashing, as shown in Figure 8.

8. Install the Termination Cap on to the Chimney Outlet Connector.

8. Attach the flex to the Chimney Inlet Connector. Use three sheet metal screws to attach the flex liner to the Connector. See Figure 9.

9. Slide Chimney Inlet Connector against the masonry wall and secure with masonry bolts. Re-drill larger holes on connector as needed. Be careful to insure that the connector is centered in the opening and the mounting holes line up with the masonry wall. If you have a framed wall in front of the masonry, use wood screws to mount the Connector to the framed wall, shown in Figure 11. If needed, add a section of direct vent pipe to the Connector in order to extend through the opening.

10. The connection between the appliance and the Chimney Inlet Connector may be completed with the section of black direct vent pipe, together with an adjustable length pipe section.

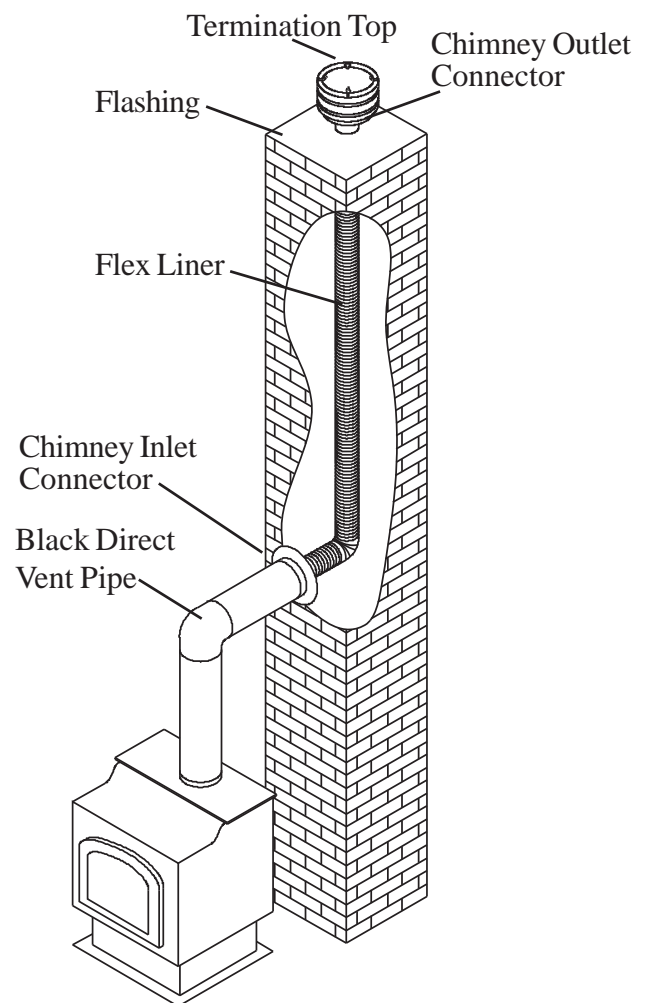

Fig 6

Cut and Bend Flashing as Appropriate to Fit Chimney

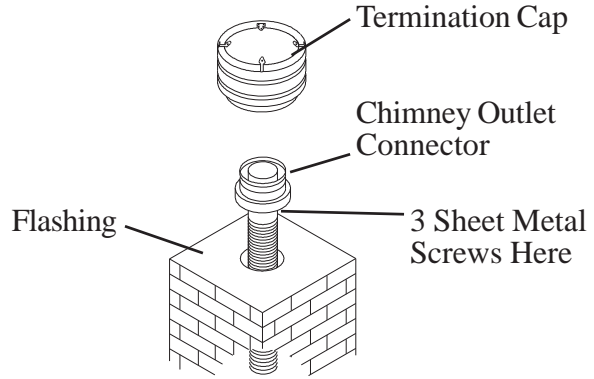
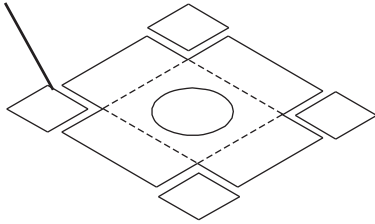

Fig 8

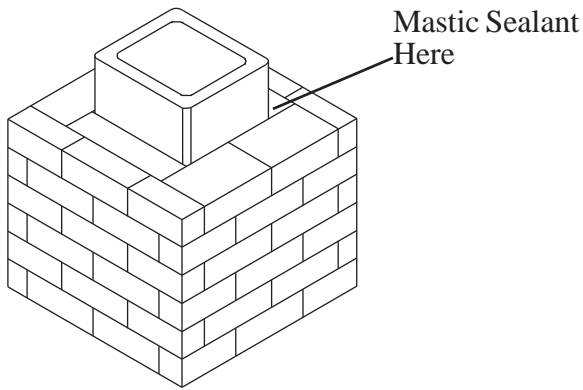

Fig 7

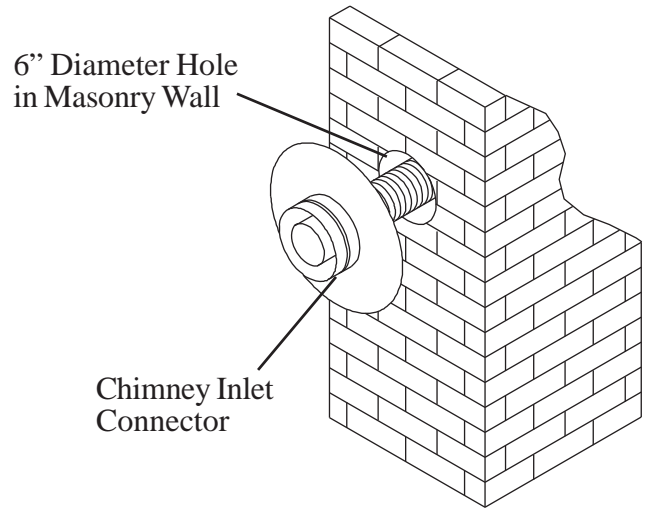

Fig 9

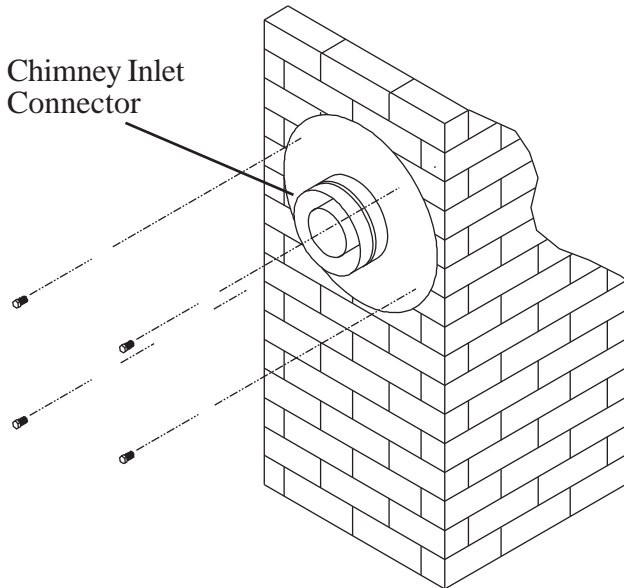

Fig 10

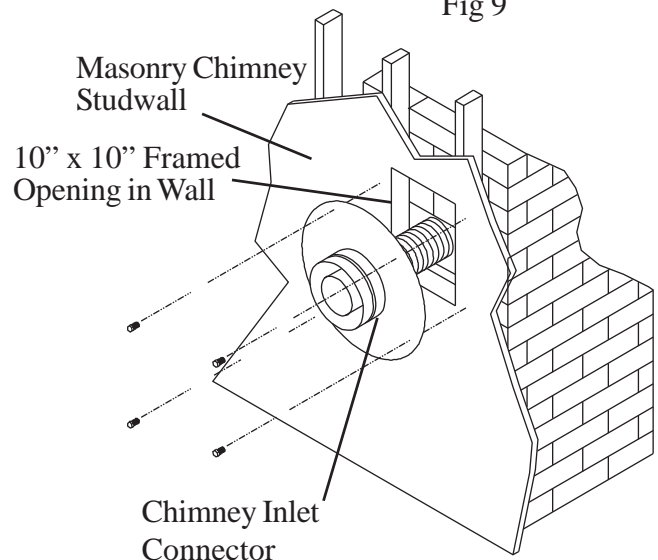

Fig 11

